



# TRICOR<sup>®</sup> TCM 0450/TCMH 0450

Coriolis Mass Flow Meter for High-Pressure Hydrogen





## **Manual-Version**

TCM\_0450\_SPECIALITY\_M\_EN\_191113\_E006

## **SW-Version**

This manual is valid for

Main SW: Mv3.40 and higher

Display SW: Dv3.40 and higher

# Index

<b>1.</b>	<b>GENERAL INFORMATION</b>	<b>6</b>
1.1.	Features	6
1.2.	Safety	7
1.2.1.	General Safety	7
1.2.2.	Special Condition of Use for Ex Installations	7
1.2.3.	Rupture Disc Handling	8
1.2.4.	Warnings in this Manual	9
1.3.	Ordering Codes and Accessories	10
1.3.1.	Ordering Code	10
1.3.2.	Accessories	11
1.4.	Measuring Principle TCM	12
1.5.	Custody Transfer	12
<b>2.</b>	<b>GETTING STARTED</b>	<b>13</b>
2.1.	Unpacking	13
2.2.	Operating Elements	13
2.2.1.	TCE 8***-wall mounted and compact version	13
2.2.2.	TCM 0450/TCMH 0450	14
2.3.	Pin Assignments	15
2.3.1.	TCE 8***-wall mounted and compact version, non-Ex	15
2.3.2.	TCE 8***-wall mounted and compact version, Ex certified	17
2.4.	Quick Start	19
2.4.1.	First Operation	19
2.4.2.	CONTROL Menu	20
2.4.3.	Using the magnet	20
<b>3.</b>	<b>INSTALLATION</b>	<b>21</b>
3.1.	Mechanical Installation	21
3.2.	Installation Guidelines	21
3.2.1.	Basic Safety Notes	21
3.2.2.	Installation Location Requirements	23
3.2.3.	Horizontal Installation	24
3.2.4.	Vertical Installation	24
3.2.5.	Installation of Multiple Meters (in Series)	25
3.2.6.	Mechanical Installation of the Electronics	25
3.2.7.	Seals of the electronics housing and the connector	25
3.3.	Electrical Installation	26
3.3.1.	Connecting TCE and TCM	26
3.3.2.	Electrical Installation of the Wall Mount Transmitter Version	27



3.3.3.	Power Supply and Grounding .....	28
3.3.4.	Control Inputs and Outputs .....	30
3.3.5.	Analog Outputs .....	31
3.3.6.	Analog Input .....	32
<b>4.</b>	<b>MANUAL OPERATION.....</b>	<b>33</b>
4.1.	Power On Sequence and Principles of Manual Control.....	33
4.1.1.	Using the Magnet .....	34
4.2.	Setup Guidelines .....	35
4.2.1.	Offset Adjustment .....	35
4.2.2.	Flow Filter .....	35
4.2.3.	CUT OFF .....	36
4.2.4.	Interaction of the Parameters .....	36
4.3.	Measuring Mode .....	37
4.3.1.	Function of the Pushbuttons .....	37
4.3.2.	Display Selection .....	37
4.3.3.	Display Resolution .....	37
4.3.4.	Resetting the Batch (TOTAL-) Value .....	37
4.3.5.	Event Logging.....	38
4.3.6.	Totalizer .....	42
4.4.	Offset Adjustment .....	43
4.5.	Control Mode.....	43
4.5.1.	Function of the Pushbuttons .....	44
4.5.2.	Submenus in the Main Menu .....	45
4.5.3.	ZERO OFFSET Menu .....	46
4.5.4.	DISPLAY Menu .....	47
4.5.5.	SETUP Menu .....	53
4.5.6.	SETUP - PARAMETER Menu .....	54
4.5.7.	SETUP - FILTER Menu.....	58
4.5.8.	SETUP - IN/OUTPUTS Menu.....	59
4.5.9.	SETUP - DATA CONFIGURATION Menu.....	68
4.5.10.	SETUP - RESET TOTAL Menu .....	69
4.5.11.	SETUP - CLEAR LOGS Menu.....	69
4.5.12.	I/O-TEST Menu.....	70
4.5.13.	SERVICE Menu .....	72
<b>5.</b>	<b>REMOTE OPERATION .....</b>	<b>73</b>
5.1.	Serial RS485 Interface .....	73
5.1.1.	Electrical Connection of RS485 Interface .....	73
5.1.2.	Usage of the TRICOR Configurator .....	73
5.1.3.	RS485-Interface-Protocol .....	73
5.2.	HART® .....	74
5.2.1.	Electrical Connection for HART® .....	74
5.2.2.	Device Description File for HART® Interface Protocol.....	74
5.3.	Foundation Fieldbus® .....	74
5.3.1.	Electrical Connection for Foundation Fieldbus® .....	74
5.3.2.	Device Description File for Foundation Fieldbus® Interface Protocol.....	74

- 6. SERVICE AND MAINTENANCE ..... 75**
- 6.1. Maintenance.....75
- 6.2. Trouble Shooting .....75
- 6.3. Maintenance and Repair Work.....76
- 6.4. Changing the fuses.....78
- 6.5. Calibration .....78
- 6.5.1. Temperature Calibration .....79
- 6.5.2. Flow Calibration.....79
- 6.5.3. Recalibration.....80
- 6.6. Cleaning .....80
- 6.7. Service.....80
- 6.8. Global Device Password.....81
- 6.9. Reloading Factory Settings .....82
- 7. LISTINGS..... 84**
- 7.1. Warranty.....84
- 7.2. Certifications and Compliances .....84
- 7.3. Technical Data .....86
- 7.3.1. Technical Data TCM 0450/TCMH 0450 Transducer.....86
- 7.3.2. Technical Data TCE 8000 Transmitter.....87
- 7.3.3. Technical Data TCE/TCM Cable.....88
- 7.3.4. Torque requirements.....88
- 7.3.5. Dimensional Drawings .....89
- 7.4. WEEE and RoHS .....90
- 7.5. Menu Structure.....90
- 7.5.1. Main Menu .....90
- 7.5.2. Menu Item „DISPLAY“ .....91
- 7.5.3. Menu Item „SETUP“ .....91
- 7.5.4. Menu Item „I/O-TEST“ .....92
- 7.5.5. Menu Item „SERVICE“ .....92
- 7.6. List of Figures.....93
- 7.7. List of Tables .....93



## 1. General Information

### 1.1. Features

The TRICOR Mass Flow Meter TCM 0450/TCMH 0450, based on the Coriolis principle, is designed and usable for high-pressure Hydrogen applications up to 1,050 bar (15,200 psi).

For this TRICOR Mass Flow Meter TCM 0450/TCMH 0450 the transmitter electronics TCE 8000 as a remote wall mount type is available. It provides following features:

- A graphic display
- Menu driven control with soft keys for easy operation (also without manual)
- Magnet hall switches for Ex areas
- Two freely programmable 4...20 mA outputs
- One freely programmable frequency output
- One control input and one control output
- RS485 interface

Available options are:

- HART® interface
- One 4...20 mA input for pressure measurement
- Pressure compensation
- Foundation Fieldbus® communications



*Fig. 1: Transducer TCM 0450/TCMH 0450 with wall-mountable transmitter electronics TCE 8001-W*

## 1.2. Safety

### 1.2.1. General Safety

All statements regarding safety of operation and technical data in this manual will only apply when the TRICOR CLASSIC Mass Flow Meter is operated correctly in accordance with this manual.

The data for Ingress Protection (IPxx) will only apply when all connectors are capped properly with the corresponding counterpart with the same or better IP rating. Cable glands must be populated with cables with the specified diameter and closed properly. The display cover must be closed.

During operation all openings of the housing must be closed unless otherwise is noted in this manual.

All electrical connections to the load and to the supply must be made with shielded cables unless otherwise is noted in this manual. The TCM must be grounded.

As a protection against fire in the positive supply, a fuse with a current rating not higher than the current carrying capacity of the cable used is required.

Before installing the Flow Meter and transmitter, the user is responsible to ensure that all wetted parts are compatible with the fluid or gas to be measured.

The user has to adhere to the instructions for installing electrical devices and corresponding instructions.

The devices described in this manual may only be connected and operated by authorized and qualified personnel.

### 1.2.2. Special Condition of Use for Ex Installations

Before installing and using TRICOR CLASSIC Mass Flow Meters in hazardous locations it is absolutely needed to read and to observe this Installation Manual and "Control drawing for hazardous areas".

In hazardous locations the enclosure lids of the transmitter must not be opened under any circumstances if the supply voltage is alive. For operating the keys the magnet must be used.

The analog and digital I/O signals are not specified for driving Ex i circuits.

When using long cables make sure that the maximum inductances and capacitances for the respective voltage or gas group are not exceeded.

---

#### **WARNING!**

All specified limiting values and parameters stated in "Installation Manual for Hazardous Areas" must be adhered to at all times. Failure to do so can cause equipment failure and can lead to serious injury or death.

---

#### **WARNING!**

Potential risk of sparking from aluminum alloy enclosure due to impact and friction. This shall be considered during installation.

---

#### **WARNING!**

The equipment contains a shunt Zener diode interface, which requires connection to a suitable earth in accordance with IEC/EN 60079-14.

---



## WARNING!

The installer shall ensure that the maximum ambient temperature of the equipment when installed is not exceeded.

## WARNING!

Process temperature range is determined by temperature class for remote version TRICOR transmitter (see "Control drawing for hazardous areas").

### 1.2.3. Rupture Disc Handling

All TRICOR CLASSIC flow meters are fitted with a rupture disc installed on the case. A rupture disc, also known as a "burst disc," is a pressure relief device to protect systems from over-pressurization. In a Coriolis flow meter, the rupture disc prevents pressure from building up inside the welded case. In the event of an extreme failure where the internal flow tubes leak, the rupture disc element will open up once the internal case pressure exceeds approximately 4 bar [58 psi].

To avoid personal injury or property damage, connect a pipe or hose to the rupture disc housing in order to direct the relieved liquid and/or gas from the meter's case through the rupture disc to a safe location, away from operators in the area. It is the user's sole responsibility for the design of adequate venting and installation of adequate vent piping or directional flow after rupture occurs with the rupture disc as intended.

Particles may discharge when the rupture disc ruptures. These particles may be part of the rupture disc itself, or other environmental matter in the system. It is the user's sole responsibility to ensure that the particles are directed to a safe location to prevent personal injury or property damage.

## WARNING!

Take care not to puncture the rupture disc when installing a pipe or fitting to the rupture disc housing, which could cause premature failure of the rupture disc.

The flow meter case is filled with a dry inert gas to prevent moisture from building up. Any puncture or other physical damage to the rupture disc would allow moisture into the meter case, compromising the integrity of the meter and potentially resulting in inaccurate measurement results or total meter failure over time.

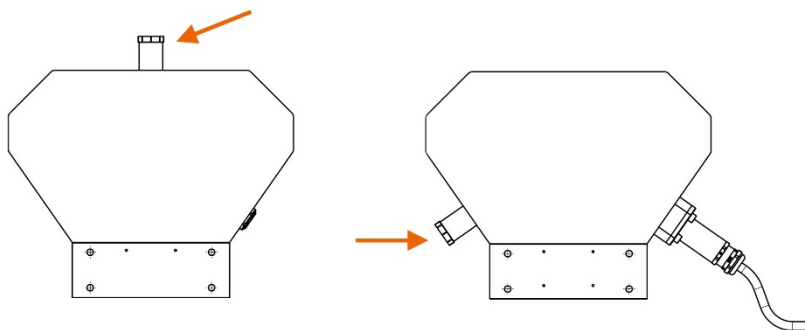

Fig. 2: Rupture disc locations vary by the meter style



Fig. 3: Warning sticker found near the rupture disc on all meters



## 1.2.4. Warnings in this Manual

---

**NOTE:**

Notes provide important information for the correct usage of the equipment. If the notes are not observed, a malfunction of the equipment is possible.

---

---

**WARNING!**

Warnings provide very important information for the correct usage of the equipment. Not observing the warnings may lead to danger for the equipment and to danger for health and life of the user

---



## 1.3. Ordering Codes and Accessories

### 1.3.1. Ordering Code

	TCE	8	X	X	X	-	X	-	X	X	X	X	-	XX	-	XX
<b>Housing</b>																
Wall mount (housing for ½" NPT cable glands)							W									
<b>Options</b>																
<b>Interface<sup>1)</sup></b>																
RS485 (Modbus RTU)											S					
RS485 (Modbus RTU) + HART®											A					
<b>Supply voltage</b>																
24 V DC + 90 ... 264 V AC (only housing S)											B					
90 ... 264 V AC (only housing W, I)											M					
<b>Transmitter options</b>																
Standard											S					
Pressure compensation, 4 ... 20 mA input											A					
<b>Cable length</b>																
3 Meters [≈ 10 ft.], standard												S				
6 Meters [≈ 20 ft.]												B				
10 Meters [≈ 33 ft.]												C				
15 Meters [≈ 49 ft.]												D				
20 Meters [≈ 65 ft.]												E				
D-SUB Connector, (housing S), separate cable required												N				
<b>EX-protection</b>																
ATEX + IECEx (Zone1)														Ex		
ATEX (Zone 2)														Exn		
cCSAus <sup>2)</sup>														Ex1		
ATEX + IECEx + cCSAus triple approval <sup>2)</sup>														Ex3		
<b>Customer options</b>																
Push-Pull connector for TCM (only for versions Exn, Ex, Ex1)																1 2

<sup>1)</sup> Other interfaces on request.

<sup>2)</sup> For Ex1 and Ex3 the transmitter is only available in aluminum housing.

TCM **0450** - **X** - **X X X X** - **X X X X** - **Ex**

**Process connections**

Autoclave 3/8" MP H

**Mechanical options**

**Medium Temperature Range**

-40 °C ... +100 °C [-40 °F ... +212 °F] S

**Pressure Range**

1.050 bar [15.200 psi] process pressure P

**Accuracy**

1 % of reading M

**Face to face length**

Standard S

**Electronics Options**

**Electronics Type**

Remote electronics, Push-Pull connector P

**Interface**

Not used Z

**Supply Voltage**

Not used Z

**Options**

Pressure compensation and 4 - 20 mA input, MID MI002/OIML R137 compliant G

No options S

**EX-Protection**

ATEX + IECEx (Zone1)	Ex
ATEX (Zone 2)	Exn
cCSAus <sup>3)</sup>	Ex1
ATEX + IECEx + cCSAus triple approval <sup>3) 4)</sup>	Ex3

**TCC** **XX** - **X X**

**Obligatory accessories for Ex3 Version**

**Connection Cable**

Connector M23 (TCE) with push pull (TCM) for EX3-Version	0 6	
3 Meters [≈ 10 ft.], standard		0 3
6 Meters [≈ 20 ft.]		0 6
10 Meters [≈ 33 ft.]		1 0
15 Meters [≈ 49 ft.]		1 5
20 Meters [≈ 65 ft.]		2 0

1.3.2. Accessories

There are currently no accessories available for the TCM 0450/TCMH 0450.

<sup>3)</sup> For Ex1 and Ex3 the transmitter is only available in aluminum housing.

<sup>4)</sup> Only with remote transmitter.



## 1.4. Measuring Principle TCM

Two parallel flow tubes inside the TCM Flow Meter are vibrating at their natural frequency in opposite direction. Any mass flow passing through the tubes will delay the vibration at the incoming side and accelerate the vibration at the outgoing side. This causes a small time shift between both ends of the tube. This time shift is measured and used to calculate the mass flow through the tubes.

By measuring the natural frequency of the tubes the density of the medium can be calculated.

As both effects are temperature dependent, the temperature is measured by means of an accurate temperature sensor for correcting the temperature effects on flow and density measurement.

As a result a Coriolis Mass Flow Meter measures directly mass flow, density and temperature of the medium. Knowing the mass flow and the density, also the volume flow can be calculated.

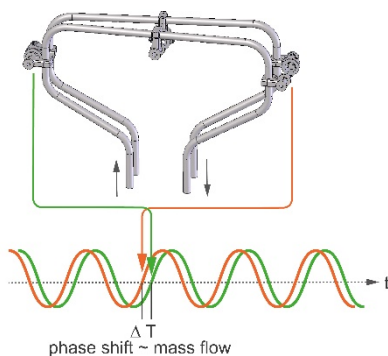

Fig. 4: Transducer TCM 0450/TCMH 0450 with wall-mount electronics TCE 8001-W

## 1.5. Custody Transfer

When the “Custody Transfer” option is selected, the following restrictions apply:

- Due to an additional Modbus command filter (additional electronic component), only a few parameters that are not critical for measuring can be written via Modbus ( “Modbus (RTU) Manual”: chapter 3.5). Read access to all values that can be read via Modbus remains unchanged from the standard version.
- The speed of the Modbus interface is fixed at 57600 baud and cannot be changed by the user.
- As soon as critical events (error messages) are written to the log, this is indicated by alternate flashing of the red and green LEDs until the user performs a manual reset (see chapter 4.3.5).
- The P button on the display cannot be operated with the magnet any more when the front cover is closed. This means no more device settings can be changed when the housing is closed and sealed.
- The two housing covers as well as the plug-in connections of the connecting cable must be secured with suitable seals to prevent unauthorized opening or unplugging.
- In case of a critical error state, all measured flow rate values are accumulated in a failure total counter (FAIL. TOTAL) instead of the totalizer (GRAND TOTAL) as long as the error state remains active.
- The standard displays have the following fixed two-line configuration:
  - Standard display: 1st line: “Current mass flow” + 2nd line: “Totalizer”
  - Alternative display: 1st line: “Temperature”+ 2nd line “Failure Total Counter”
- Remote control is possible exclusively via RS485/Modbus RTU (HART® or Foundation Fieldbus® are permanently inactive)
- The control input (CTRL IN) is permanently inactive (=OFF)

## 2. Getting Started

### 2.1. Unpacking

Verify that you have received the following items:

- TCM 0450/TCMH 0450
- TCE 8001-W
- Instruction manual (printed booklet or [www.tricorflow.com/support/downloads](http://www.tricorflow.com/support/downloads))

### 2.2. Operating Elements

#### 2.2.1. TCE 8\*\*\*-wall mounted and compact version

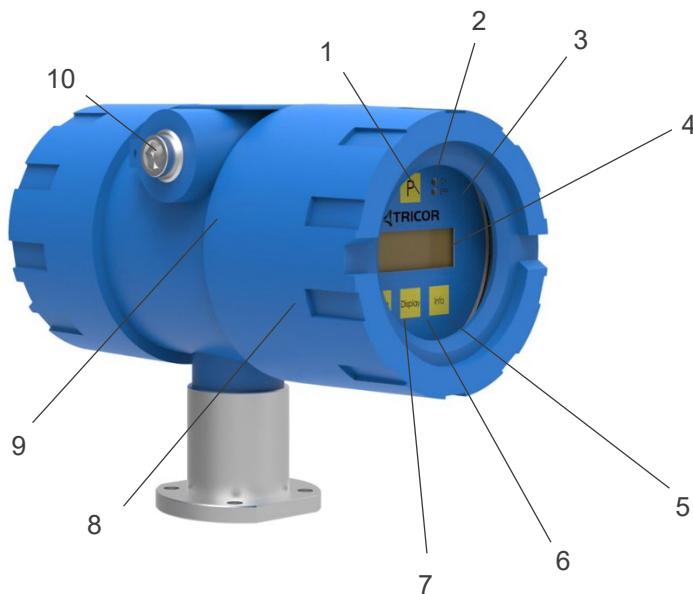

Fig. 5: Operating Elements TCE 80xx-W

- 1 = Pushbutton “P”, activates/selects the different menus and confirms the settings
- 2 = LED “OK”, flashes green when there is no error
- 3 = LED “ERR”, flashes red when an error occurs
- 4 = Display
- 5 = Pushbutton “Info”, normal: selects the error menu, setup mode: softkey
- 6 = Pushbutton “Display”, normal: toggles the display, setup mode: softkey
- 7 = Pushbutton “Reset”, normal: resets the BATCH TOTAL counter, setup mode: softkey
- 8 = Front cover
- 9 = Set screw for front cover (varying position)
- 10 = Screw for protective ground

Wall mount electronics only (not shown on the picture):

- Cable to the TCM 0450/TCMH 0450 sensor, length as ordered (standard: 3 m [10 ft.])
- Wall mounting bracket



## 2.2.2. TCM 0450/TCMH 0450

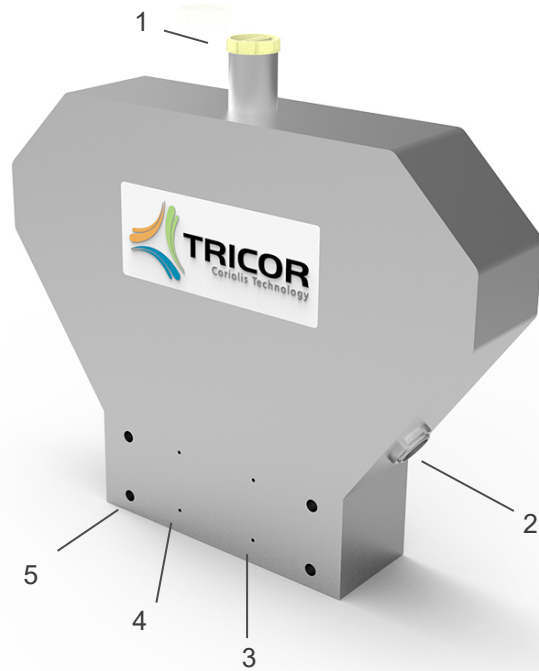

Fig. 6: Bedienelemente TCM 0450/TCMH 0450

- 1 = Locking screw for rupture disc
- 2 = Socket for cable to the TCE
- 3 = Fluid output, Autoclave
- 4 = Fluid input, Autoclave
- 5 = Mounting holes (4 x)

## 2.3. Pin Assignments

### 2.3.1. TCE 8\*\*\*-wall mounted and compact version, non-Ex

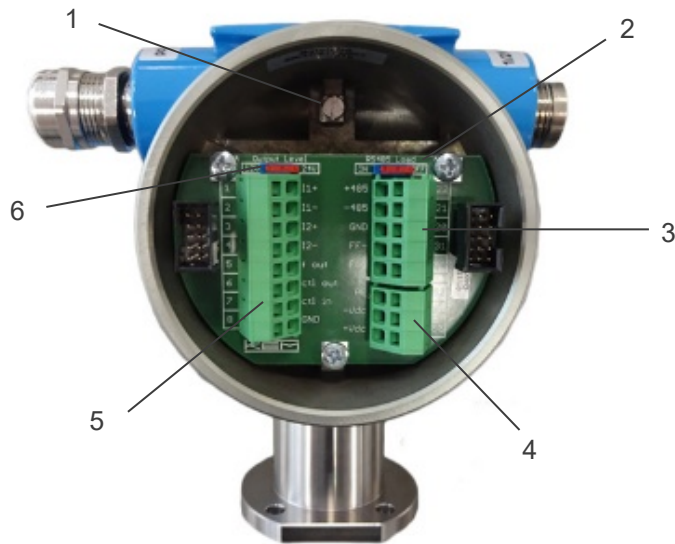

Fig. 7: Electrical terminals TCE 8\*\*\*-W and compact version

- 1 = Terminal screw for protective ground
- 2 = Switch for terminating resistor for the RS485 interface
- 3 = Terminal block for interface
- 4 = Terminal block power supply
- 5 = Terminal block for I/O signals
- 6 = Switch for output level (12 V/24 V) of the frequency and control output



## TCE Terminal Connections

1	+I1	Current loop 1 positive terminal
2	-I1	Current loop 1 negative terminal
3	+I2	Current loop 2 positive terminal
4	-I2	Current loop 2 negative terminal
5	F <sub>OUT</sub>	Frequency/pulse output
6	CTL <sub>OUT</sub>	Control output
7	CTL <sub>IN</sub>	Control input
8	GND	Ground (for pins 5 through 7)
20	COMMON	Common (for pins 21 and 22)
21	-RS485	RS485 negative line
22	+RS485	RS485 positive line
30	COMMON	Common (for pins 31 and 32)
31	FF-	Foundation Fieldbus® negative line
32	FF+	Foundation Fieldbus® positive line

### 24 V DC Supply

50	+V DC	Positive supply voltage (24 V DC)
51	-V DC	Supply ground
52	PE	Protective Ground

### 100 ... 240 V AC Supply

90	L	Phase (AC voltage)
91	N	Neutral
52	PE	Protective Ground

---

### NOTE:

An active pressure compensation is not needed with the TCM 0450/TCMH 0450 Coriolis meter because of its extremely low drifts with pressure changes.

Nevertheless, if the option "Pressure Compensation" is used the current loop 1 (Terminal 1 and 2) works as an input.

---



### 2.3.2. TCE 8\*\*\*-wall mounted and compact version, Ex certified

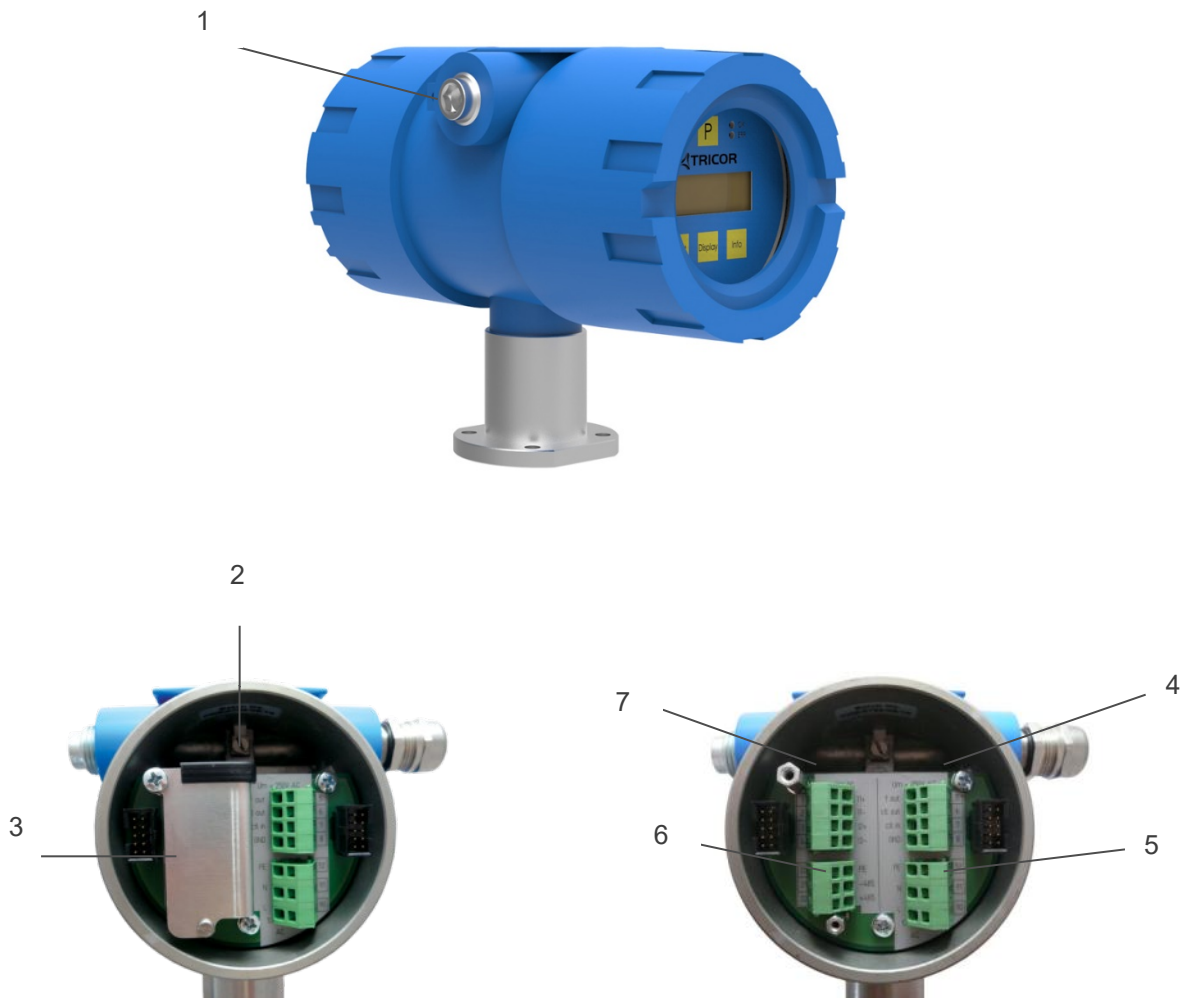

Fig. 8: Electrical terminals TCE 8\*\*\*-W-\*-Ex

- 1 = Terminal screw for protective ground
- 2 = Terminal screw for protective ground
- 3 = Protective cover
- 4 = Terminal block for digital I/O signals ( $U_M = 250 \text{ V DC}$ )
- 5 = Terminal block power supply ( $U_M = 250 \text{ V DC}$ )
- 6 = Terminal block for interface ( $U_M = 30 \text{ V DC}$ )
- 7 = Terminal block for analog I/O signals ( $U_M = 30 \text{ V DC}$ )



## TCE Terminal Connections

### Terminals with $U_M = 30\text{ V DC}$

1	+I1	Current loop 1 positive terminal
2	-I1	Current loop 1 negative terminal
3	+I2	Current loop 2 positive terminal
4	-I2	Current loop 2 negative terminal
20	COMMON	Common (for pins 21 and 22)
21	-RS485	RS485 negative line
22	+RS485	RS485 positive line
30	COMMON	Common (for pins 31 and 32)
31	FF-	Foundation Fieldbus® negative line
32	FF+	Foundation Fieldbus® positive line

### Terminals with $U_M = 250\text{ V DC}$

5	F <sub>OUT</sub>	Frequency/pulse output
6	CTL <sub>OUT</sub>	Control output
7	CTL <sub>IN</sub>	Control input
8	GND	Ground (for pins 5 through 7)

### 24 V DC Supply

50	+V DC	Positive supply voltage (24 V DC)
51	-V DC	Supply ground
52	PE	Protective Ground

### 100...240 V AC Supply

90	L	Phase (AC voltage)
91	N	Neutral
52	PE	Protective Ground

---

#### NOTE:

An active pressure compensation is not needed with the TCM 0450/TCMH 0450 Coriolis meter because of its extremely low drifts with pressure changes.

Nevertheless, if the option "Pressure Compensation" is used the current loop 1 (Terminal 1 and 2) works as an input.

---

## 2.4. Quick Start

---

### WARNING!

As for safety and accuracy reasons many precautions must be taken, read chapter 3 carefully before installing the TCM.

---

In case the TCM has only to be operated without flow for testing or learning purpose, at least the following connections have to be made (see chapter 3.3):

- Connect the TCE to the TCM (only required with the separate version)
- Connect the supply voltage
- The various inputs and outputs as well as the interface may be connected as well, if those features are required.

---

### WARNING!

If the TRICOR CLASSIC Mass Flow Meter is connected to a bigger system, for your personal safety connect the protective ground as well!

---

---

### WARNING!

In hazardous areas it is not allowed to operate the TRICOR CLASSIC Coriolis Mass Flow Meter without proper wiring in accordance with chapter 3.3.6 and with the housing not properly closed!

---

### 2.4.1. First Operation

Make sure that all mechanical and electrical connections are made properly.

Switch on the power supply. The LED "OK" will flash green.

After the power up sequence the display shows the preselected values (ex factory: "FLOW" and "BATCH")

Switch on the flow. The value indicated in the display should be positive.

In case of an error the LED "ERR" will flash red.

As soon as the TCM has reached the operating temperature, make the zero point calibration (see chapter 4.2.1 and 4.5.3 for detailed information):

- Switch off the flow
- Wait until the flow through the TCM is zero
- Start the zero offset calibration in the "ZERO OFFSET" menu
- Wait until the offset procedure is finished
- Switch on the flow again

The display can be altered by pressing the pushbutton "Display".

The internal device status can be viewed by pressing the pushbutton "Info".

If the function is activated, the BATCH reading can be reset to zero by pressing the pushbutton "Reset".

To open the control menu press button "P" for three seconds.



## 2.4.2. CONTROL Menu

In the “CONTROL” menu all configurations can be made. This includes configuration of the analog and digital outputs, customizing the display and other settings.

The menu itself is self-explaining; the function of the softkeys is indicated in the display above the pushbuttons.

To enter the “CONTROL” menu press the pushbutton “P” for three seconds.

If a global access code is set, the “CONTROL” menu is completely locked (see chapter 6.8).

With no global access code the submenu “DISPLAY” can be entered without a password as any changes in this submenu will not affect the operation of the TCM.

The submenus “ZERO OFFSET”, “SETUP”, “I/O-TEST” and “SERVICE” are password protected for avoiding unintentional changes of the operating parameters.

For “ZERO OFFSET”, “SETUP” and “I/O-TEST” the password is “2207”, for “SERVICE” refer to chapter 6.

Change the indicated number “2206” with the softkey “UP” to “2207” and confirm with “P”.

Select the desired submenu with the softkeys and confirm with “P”.

Every setting must be confirmed with “P” for storing the setting or with “EXIT” for exiting without storing.

For leaving the “SETUP” menu press “EXIT” until the TCE returns to the main level.

---

**NOTE:**

With the “Custody Transfer” option, no settings can be configured when the front cover is closed since the P button is deactivated.

---

## 2.4.3. Using the magnet

The explosion-proof variants with the blue Ex d housings provide a magnet to be able to operate the pushbuttons without opening the display cover.

In hazardous, wet and dusty areas the display cover must not be opened to operate the pushbuttons.

Beside every pushbutton there is a hall sensor which can be operated via the magnet attached to the housing.

For operating the pushbuttons hold the magnet to the glass.

The best positions for operating the keys are:

Pushbutton	Position
P	left upper edge of the yellow area
Reset	lower edge of the yellow area
Display	lower edge of the yellow area
Info	lower edge of the yellow area



---

**NOTE:**

The P button cannot be operated with the magnet with the “Custody Transfer” option!

---

## 3. Installation

### 3.1. Mechanical Installation

In accordance with this manual the user should select the installation position which fits the application best. To ensure the highest degree of accuracy and repeatability, care should be taken to affix the TRICOR products in a stable process site and minimize the amount of vibration in the installation environment.

### 3.2. Installation Guidelines

Coriolis Mass Flow Meters measure the flow of a gas by vibrating the medium perpendicular to the flow direction and measuring the effect of the inertial force of the medium. Consequently, for best performance the meter must be decoupled from external vibrations and the medium must be homogenous.

#### **External vibration:**

In case of (possible) external vibrations connect the meter mechanically rigidly to a non-vibrating point or – if this is not possible – connect it by means of vibration dampers.

The TCM 0450/TCMH 0450 has to be mounted using the mounting holes, and must not be fixed directly to the external tubing.

Piston pumps and other pumps producing a strongly pulsating flow should be decoupled hydraulically via longer pipes, flexible tubes or other measures.

#### **Inhomogeneous media:**

In case the medium contains liquid droplets or solid particles make sure that those droplets or particles do not accumulate inside the meter. For this, the meter has to be mounted with tubes coming from the bottom side.

#### 3.2.1. Basic Safety Notes

---

#### **CAUTION!**

##### **Hot surfaces resulting from hot process media**

Risk of burns resulting from surface temperatures above 70 °C [155 °F].

Take appropriate protective measures, for example contact protection.

Make sure that protective measures do not cause the maximum permissible ambient temperature to be exceeded. Refer to the information in “Technical Data” (see chapter 7.3).

---

#### **NOTE:**

Hot surface is only an issue for media or ambient temperature above 50 °C [122 °F].

---

#### **WARNING!**

##### **Wetted parts unsuitable for the process media**

Risk of injury or damage to device.

Hot, toxic and corrosive media could be released if the process medium is unsuitable for the wetted parts.

Ensure that the material of the device parts wetted by the process medium is suitable for the medium. Refer to the information in “Technical Data” (see chapter 7.3).

---



---

**NOTE:****Material compatibility**

The manufacturer can provide you with support concerning selection of sensor components wetted by process media. However, you are responsible for the selection of components. The manufacturer accepts no liability for faults or failures resulting from incompatible materials.

---

**WARNING!****Unsuitable process connections**

Risk of injury or poisoning.

In case of improper mounting hot, toxic and corrosive process media could be released at the connections.

Ensure that process connections (such as flange gaskets and bolts) are suitable for connection and process media.

---

**WARNING!****Exceeded maximum permissible operating pressure**

Risk of injury or poisoning.

The maximum permissible operating pressure depends on the device version, pressure limit and temperature rating. The device can be damaged if the operating pressure is exceeded. Hot, toxic and corrosive process media could be released.

Ensure that maximum permissible operating pressure of the device is not exceeded. Refer to the information on the sensor nameplate and/or in "Technical Data" (see chapter 7.3).

---

**WARNING!****Unprotected cable ends**

Risk of explosion through unprotected cable ends in hazardous areas.

Protect unused cable ends in accordance with IEC/EN 60079-14.

---

**WARNING!****Loss of explosion protection**

Risk of explosion in hazardous areas if the device is open or not properly closed.

Close the device as described in "Electrical Installation" (see chapter 3.3).

---

**CAUTION!****External stresses and loads**

Damage to device by severe external stresses and loads (e.g. thermal expansion or pipe tension). Process media can be released.

Prevent severe external stresses and loads from acting on the device.

---

### 3.2.2. Installation Location Requirements

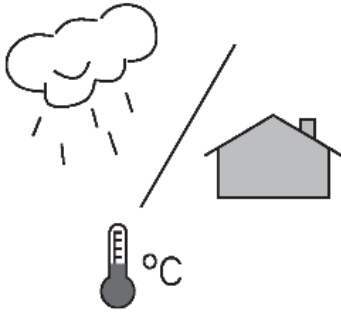

TRICOR TCMP Series Flow Meters has IP65 rating by default. With the optional IP67/NEMA 4X enclosure rating the meters are suitable for indoor and outdoor installations.

#### **Process pressure and medium temperature**

If applicable, make sure that specifications for rated process pressure (PS) and medium temperature (TS) plus ambient temperature that are indicated on the device nameplate/label will not be exceeded.

#### **Aggressive atmospheres**

Ensure that the device is suitable for the application and that it is installed where there is no risk of penetration of aggressive vapors.

#### **Direct sunlight**

Prevent the device from overheating or materials becoming brittle due to UV exposure by protecting it from direct sunlight. Make sure that the maximum permissible ambient temperature is not exceeded. Refer to the information in “Technical Data” (see chapter 7.3).

---

#### **WARNING!**

##### **Equipment used in hazardous areas**

Risk of explosion in hazardous areas.

Special requirements apply to the location and installation of the device. See “Electrical Installation” (chapter 3.2.1 to 3.3.2).

---

#### **WARNING!**

##### **Strong vibrations**

Risk of explosion in hazardous areas.

In plants with strong vibrations, mount the transmitter in a low vibration environment.

---

#### **CAUTION!**

##### **Strong vibrations**

Damage to device

In plants with strong vibrations, mount the transmitter in a low vibration environment away from the sensor.

---



## 3.2.3. Horizontal Installation

The horizontal installation is the recommended installation.

The TCM 0450/TCMH 0450 has to be mounted using the four mounting holes. Fix the meter to a solid, non-vibrating surface as close to the meter as possible.

If no non-vibrating surface is available, vibration dampers might be recommended.

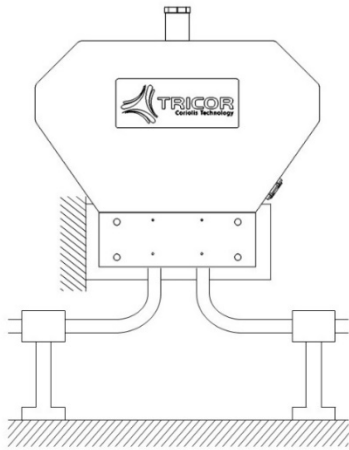

Fig. 9: Recommended Horizontal Installation

## 3.2.4. Vertical Installation

Mounting the meter vertically is not allowed.

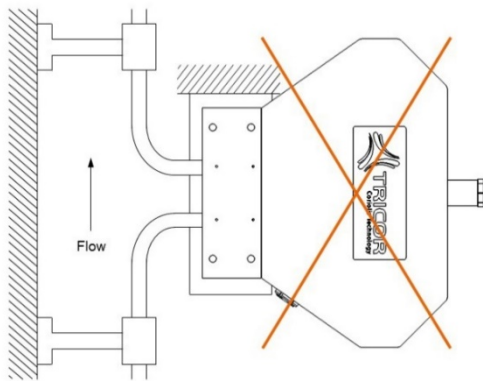

Fig. 10: Vertical Installation



### 3.2.5. Installation of Multiple Meters (in Series)

It should be avoided to mount multiple meters directly next to each other (in series). Meters of the same type run at similar frequencies. Therefore it's possible for meters of the same type to cross talk and disturb the measurement. To avoid these problems the following recommendations should be followed:

- Increase the distance from meter to meter to  $\geq 1\text{m}$
- Use independent, vibration-free and solid grounds to mount the meters

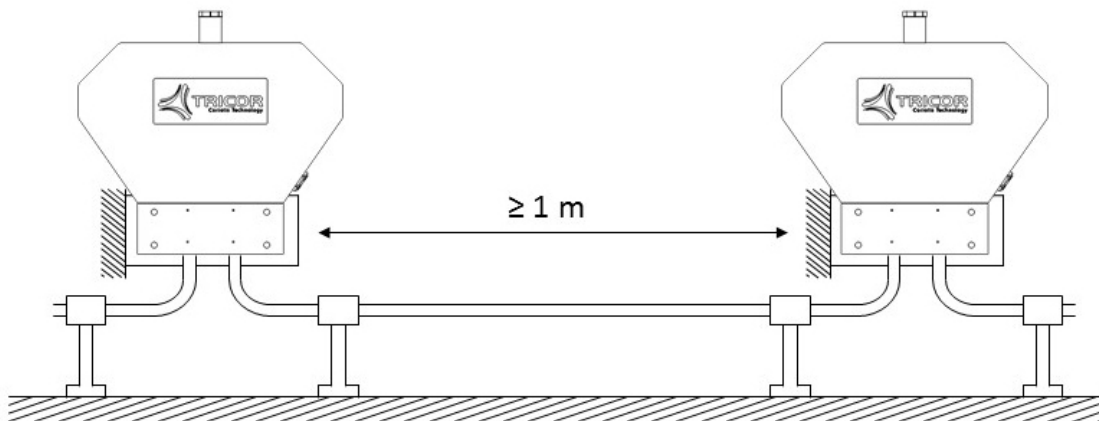

Fig. 11: Vertical Installation

### 3.2.6. Mechanical Installation of the Electronics

The wall mount TCE is to be mounted on the wall with 2 screws with 5 mm diameter, about 40 mm apart. For exact dimensions refer to chapter 7.3.5.

**WARNING!**

For mounting the TCM in hazardous areas refer to the “Control drawing for hazardous areas”.

### 3.2.7. Seals of the electronics housing and the connector

The custody transfer devices must be protected against unauthorized manipulation. In order to seal the covers of the electronics housing, holes are provided in the housing body as well as in the safety bolts.

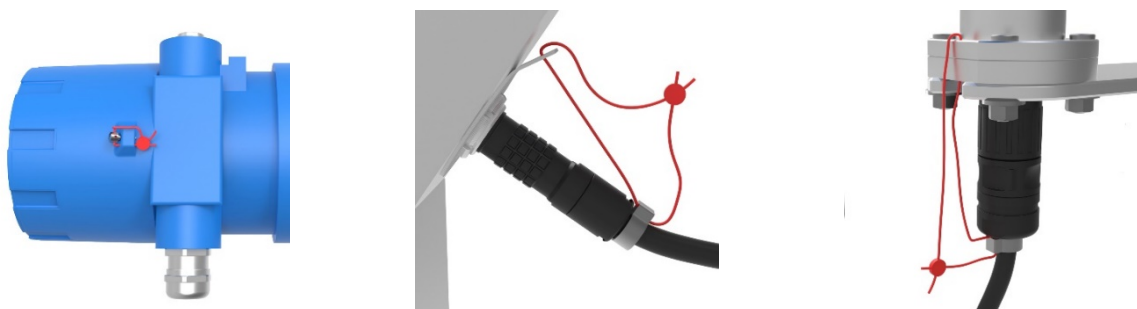

Fig. 12: Seals of the electronics housing and the connector



## 3.3. Electrical Installation

Make sure that the TCM is properly mounted and the process input and output are connected before making the electrical connections.

The TCM must be grounded.

The TCE requires a regulated power supply of 24 V DC or a mains voltage of 100 to 240 V AC, depending on the version.

---

### **WARNING!**

Never connect a 24 V only version to the mains supply or vice versa!

---

The digital inputs and outputs are referred to GND and to the ground potential of the DC supply (= negative pole). The AC supply terminals are electrically isolated from all inputs and outputs.

The ground potential GND is connected to protective ground via a 1 k $\Omega$  resistor. The resistor will thermally withstand a potential difference of up to 30 V between PE and GND but for proper operation this difference should be limited to 5 V.

To connect the TCE, shielded cables must be used. The shield should be connected to the case. If the TCM is installed in bigger systems and the shield must not present a DC connection for avoiding high ground loop currents, make the ground connection of the shield via a capacitor of e.g. 100 nF.

---

### **WARNING!**

Improper grounding and shielding may lead to bad EMC behavior or danger to your health!

---

### **NOTE:**

Make sure that all cable and wires are connected and fixed properly before applying power to the TCE.

---

### **WARNING!**

Always switch off the voltage supply before you wire the analog or digital in- and outputs or communication interface.

---

### 3.3.1. Connecting TCE and TCM

TCM and TCE have to be electrically connected properly. Otherwise, the TCE electronics will show an error message.

Typically, the connecting cable is part of the TCE electronics and unchangeably fixed to it.

With the variant usable in hazardous areas (Ex3 version), an additional connecting cable is provided which is equipped with plug connectors at both ends.

The M23 plug connectors is meant to be plugged into the corresponding socket at the TCE and needs to be locked or unlocked by a quarter turn of its union nut.

The electrical connection to the TCM 0450/TCMH 0450 is done by means of a push-pull plug connector that is automatically locked to the socket.

Just push the plug into the socket until it is notable engaged.

For disconnecting just pull the plug housing. The locking is released automatically.

### 3.3.2. Electrical Installation of the Wall Mount Transmitter Version

Connect the TCM to the TCE (see chapter 3.3.1, remote version only).

Open the safety screw at the display cover of the TCE with the provided Allen key.

Remove the display cover of the TCE by turning it counter clockwise.

Pull out the display.

Prepare the cable for installation:

- Separate the single wires for about 12 cm [4¾ inches]
- Strip the end and cover it with a cable end sleeve
- Connect an about 7 cm [2¾ inches] long stranded wire to the shield

Feed the cable through the cable gland.

Connect the shield to the PE screw.

---

**NOTE:**

In bigger installations a separate PE connection with a high cross section ( $> 1.5 \text{ mm}^2$ ) is recommended for avoiding high equalizing currents in the shield.

---

Connect the individual conductors to the cage clamp terminals as required.

Push a small screwdriver into the upper (smaller) opening of the terminal, feed the cable into the bigger opening and pull out the screwdriver.

For the right connections refer to chapter 2.3 and chapter 3.3.2.

Adjust the position of the cable in the cable gland in that way that the single conductors remain short but free of tension and fix the cable in the cable gland.

Put in the display again. The display can be positioned in four different orientations, separated by 90°.

Perform – if necessary – a function test and make the necessary settings (in non Ex area only, see chapter 4.5).

Close the display cover and tighten properly the cable glands before applying the power..

Fasten the safety screw if necessary.

---

**WARNING!**

The Ex d protection of the housing is void, if any of the cable glands is not closed properly!

---

**NOTE:**

The supply terminals and the digital I/O terminals are rated for  $U_M = 250 \text{ V}$  whereas the analog input and output and the interface terminals are rated for  $U_M = 30 \text{ V DC}$ .

---



## **WARNING! (FOR HAZLOC CSA INSTALLATION )**

### **Unsuitable cables, cable glands and/or plugs**

Risk of explosion in hazardous areas.

Use only cable glands/plugs that comply with the requirements for the relevant type of protection. Replace the cable gland for the supply and I/O-cables by a CSA or UL certified seal fitting within 18" from the housing. Tighten the cable glands in accordance with the torques specified in "Technical Data TCE 8000 Transmitter" (chapter 7.3.2).

Close unused cable inlets for the electrical connections.

When replacing cable glands use only cable glands of the same type.

After installation check that the cables are seated firmly.

## 3.3.3. Power Supply and Grounding

### 3.3.3.1. 24 V DC Power Supply

The TCE requires a regulated power supply of 24 V DC.

The power supply input of the TCE is protected by a fuse. As a protection against fire in case of a short in the supply cable, the output of the power supply must be equipped with a fuse with a rating not higher than the current carrying capacity of the cable used.

For connecting the TCE use shielded cables. If several cables are used, each cable should be shielded properly.

For operation in hazardous areas a good connection of PE of PE is mandatory. The cross section of the PE cable should be at least equivalent to the cross section of the supply cable or to 1 mm<sup>2</sup>, whichever is higher.

Connect the ground of your power supply to terminal 51 and the 24 V DC to terminal 50 (see Fig. 13).

## **WARNING!**

Applying 250 V AC to the DC supply terminals (50, 51) will not affect the Ex safety of the TCE or TCM, but will damage the supply circuit of the TCE!

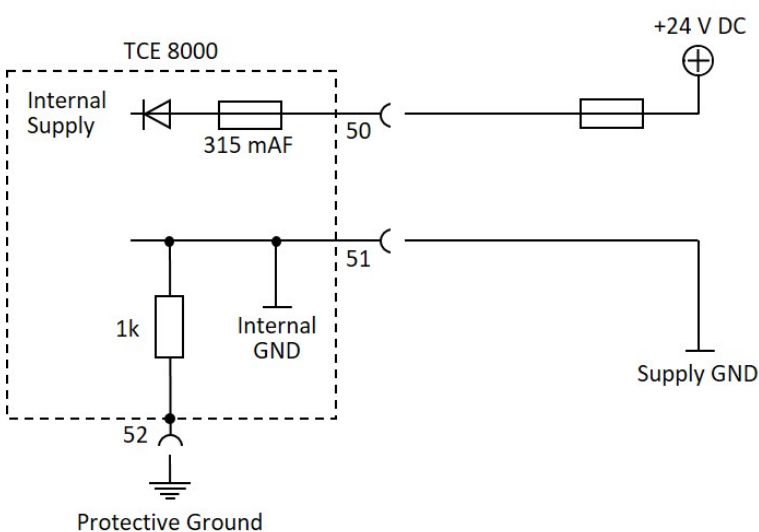

Fig. 13: Wiring diagram for power connections, DC operation

Terminal	Description
50	Positive supply voltage, 24 V DC, referred to pin 51
51	Negative supply voltage
52	Protective ground

The ground terminals 8 and 51 are internally connected together.

Ground and protective ground are internally connected via a 1 kΩ resistor. The resistor will thermally withstand a potential difference of up to 30 V between PE and GND but for proper operation this difference should be limited to 5 V.

### 3.3.3.2. 100...240 V AC Mains Supply

The AC version of the TCE requires a nominal power supply of 100...240 V AC and operates over a range of 90 ... 264 V AC.

The power supply input of the TCE is protected by a 1 A slow blow fuse. As a protection against fire in case of a short in the supply cable, the output of the power supply must be equipped with a fuse with a rating not higher than the current carrying capacity of the cable used.

For the mains powered TCE a good connection of PE is mandatory. The cross section of the PE cable should be at least equivalent to the cross section of the supply cable or to 1 mm<sup>2</sup>, whichever is higher.

### 3.3.3.3. Finishing the transmitter connection

Connect the supply to terminal 91 (neutral) and 90 (phase) (see Fig. 14).

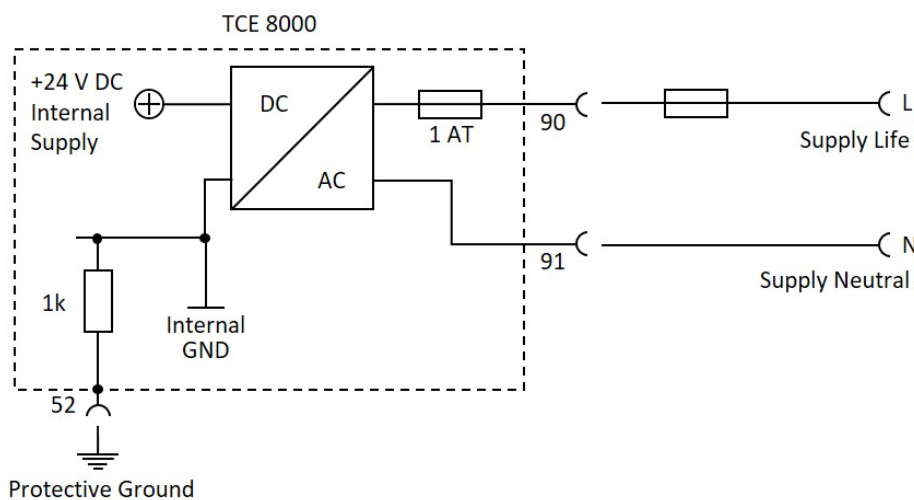

Fig. 14: Wiring diagram for power connections, AC operation

Terminal	Description
90	Mains phase, referred to pin 91
91	Mains neutral
52	Protective ground

The ground terminal 8 is not connected to terminal 91.

## 3.3.4. Control Inputs and Outputs

The digital I/O terminals are designed for a rated voltage of 250 V AC.

### WARNING!

Applying 250 V AC to the digital I/O terminals (5, 6, 7, 8) will not affect the Ex safety of the TCE or TCM, but will damage the I/O board of the TCE!

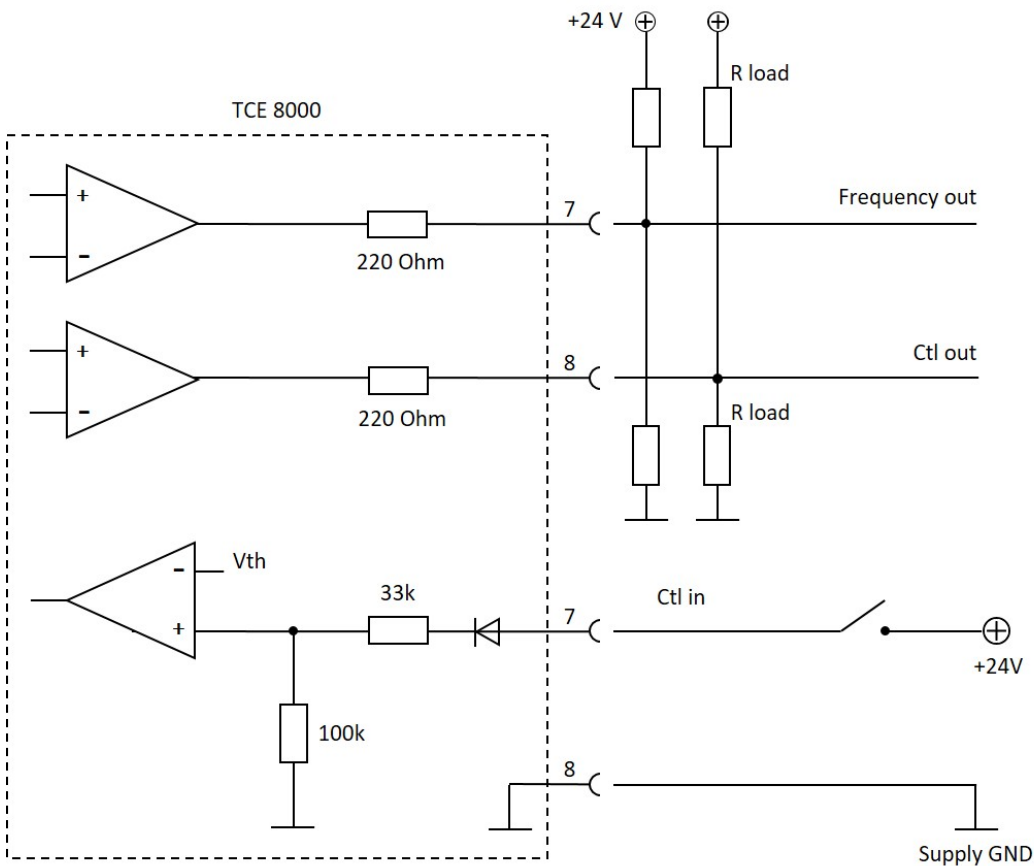

Fig. 15: Wiring diagram for digital I/O connections

Terminal	Description
5	Frequency output, active, referred to pin 8
6	Status output, active, referred to pin 8
7	Control input, active "HIGH", referred to pin 8
8	Ground potential for digital I/O- pins.

The frequency and control outputs are active push-pull outputs with an output resistance of 220 Ω. They can be loaded to the positive supply or to ground. For a high output swing the load resistors  $R_{load}$  should not be lower than 1 kΩ.

In case of a load resistor to ground the output voltages are:

$$V_{high} = V_{supply} * \frac{R_{load}}{220 \Omega + R_{load}}$$

$$V_{low} < 1 V$$

In case of a load resistor to the positive supply the output voltages are:

$$V_{high} > V_{supply} - 1 V$$

$$V_{low} = V_{supply} - V_{supply} * \frac{R_{load}}{220 \Omega + R_{load}}$$

The control input requires a high voltage of minimum 6.5 V and a minimum input current of 0.1 mA.

The ground terminals 8 and 51 are internally connected together.

Ground and protective ground are internally connected via a 1 kΩ resistor. The resistor will thermally withstand a potential difference of up to 30 V between PE and GND but for proper operation this difference should be limited to 5 V.

### 3.3.5. Analog Outputs

The TCE 8000 provides two independent passive 4 ... 20 mA current loops CURRENT 1 and CURRENT 2.

The current loops are isolated from each other and from the power supply.

For operation an external supply of 8 ... 30 V DC (nominal 24 V DC) is required.

The minimum voltage between terminal 1 and 2 or 3 and 4 respectively is 8 V.

The minimum load resistance is 0 Ω, the maximum is determined by the supply voltage.

At a given supply voltage the maximum load resistance can be calculated as:

$$R_{load} (max) = \frac{V_{supply} - 8 V}{22 mA}$$

For +24 V DC minus 10 % supply this gives a maximum value of 620 Ω.

With a given load resistance, the minimum supply voltage can be calculated as:

$$V_{supply} (min) = 8 V + R_{load} * 22 mA$$

#### WARNING!

Applying more than 30 V to any of the inputs or outputs will damage the TCE and destroy the protection of the TCM!

If more than 30 V have been applied to any of the analog output pins, the unit must be returned to KEM/AWL for repair as the safety barrier might be destroyed!

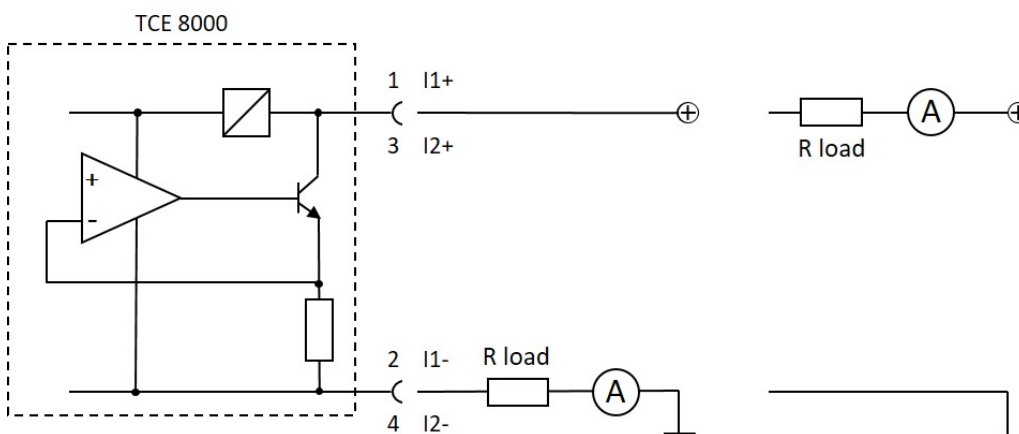

Fig. 16: Wiring diagram for 4 ... 20 mA current loop



Terminal	Description
1	Positive terminal of the passive 4 ... 20 mA loop 1
2	Negative terminal of the passive 4 ... 20 mA loop 1
3	Positive terminal of the passive 4 ... 20 mA loop 2
4	Negative terminal of the passive 4 ... 20 mA loop 2

As the terminals are floating, the load resistor and the current meter can be placed in the positive or in the negative supply rail.

Connect the shield of the cables to protective ground (terminal 52).

### 3.3.6. Analog Input

The TCE 8000 with “PRESSURE COMPENSATION” option provides one passive 4 ... 20 mA output CURRENT 2 and one active 4 ... 20 mA current input CURRENT 1.

The current input is designed to drive a 2-wire passive 4 ... 20 mA pressure sensor. It provides a minimum driving voltage of 16 V.

The negative terminal (2) is internally connected to GND (non Ex version) or to PE (Ex version).

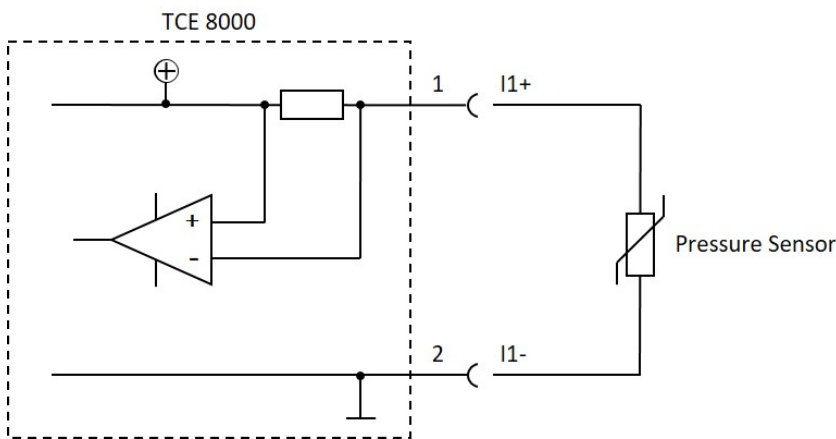

Fig. 17: Wiring diagram for 4 ... 20 mA current input

Terminal	Description
1	Positive terminal for a passive 4 ... 20 mA pressure sensor
2	Negative terminal for a passive 4 ... 20 mA pressure sensor

Connect the shield of the cables to protective ground (terminal 52).

#### **WARNING!**

The analog input is not short-circuit proof. Load currents above 35 mA (permanent load) or above 50 mA (short-time load) can cause damages.



## 4. Manual Operation

### 4.1. Power On Sequence and Principles of Manual Control

The power up sequence gives the following information, each for about two seconds:

**CORIOLIS**  
**TRICOR**

**TCE 8000**

**SENSOR TYPE**  
**TCM 0450**

**SW MAIN**  
**Rev.: V3.45**

This indicates the SW version of the main processor.

**SW DISPLAY**  
**Rev.: V3.45**

This indicates the SW version of the display processor.

**READY**

If changes to the settings were made before the last power down and not saved to the backup EEPROM, the following message appears:

**\*\*\* ..... WARNING ..... \*\*\***  
**NO ACTUAL RAM BACKUP**  
**SEE MANUAL**  
**OK**



If no pushbutton is pressed the warning will disappear automatically after 10 seconds.

The absence of valid backup data has no influence on the reliability of operation of the meter. The backup is just used to restore the last operation setting in case important parameters of the TCE have misadjusted

For further information refer to chapter 4.5.9.

Now the TCE 8000 switches to the measuring mode, displaying the default screen:

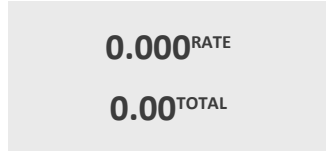

The green LED "OK" flashes with a one second period. In case of an error the red LED "ERR" flashes.

If the "Custody Transfer" option is selected and critical error messages have been recorded in the log file but there is currently no error state, the red and green LEDs flash alternately until all critical ERR messages in the log file have been reset (see chapter 4.3.5).

In manual control the TCE is menu driven and provides two operational modes, the "Measuring Mode" and the "Control Mode".

In the measuring mode the display shows the preselected measured values and all four pushbuttons have the function printed on them. The switch over between the different display views can be made at any time, by pressing the "Display" button, without influencing neither the measurement nor the digital or analog outputs.

In the control mode the three pushbuttons below the display have varying functions. The actual function is indicated in the display, just above the pushbutton.

In the control menu all necessary settings can be made, if the "Custody Transfer" option was not selected.

The control menu contains the submenus "ZERO OFFSET", "DISPLAY", "SETUP", "I/O-TEST", "SERVICE" and "FACTORY".

For protecting the TRICOR CLASSIC Mass Flow Meter against unintentional changes by unauthorized personnel, the menus "ZERO OFFSET", "SETUP" and "I/O-TEST" are protected by a user password, the menu "SERVICE" by a service password and the menu "FACTORY" by a factory password.

Additionally, a global access code can be set that locks the TRICOR CLASSIC Mass Flow Meter completely.

For the description of the control menu see chapter 4.5.

## 4.1.1. Using the Magnet

The explosion-proof variants with the blue Ex d housings provide a magnet to be able to operate the pushbuttons without opening the display cover.

In hazardous, wet and dusty areas the display cover must not be opened to operate the pushbuttons.

Beside every pushbutton there is a hall sensor which can be operated via the magnet attached to the housing.

For operating the pushbuttons hold the magnet to the glass.

The best positions for operating the keys are:

Pushbutton	Position
P	left upper edge of the yellow area
Reset	lower edge of the yellow area
Display	lower edge of the yellow area
Info	lower edge of the yellow area



**NOTE:**

The P button cannot be operated with the magnet with the “Custody Transfer” option!

## 4.2. Setup Guidelines

Ex factory the TRICOR CLASSIC Mass Flow Meters come with a setup optimized for normal applications. In more than 90 % of the applications no further optimization except a zero offset adjustment is required.

The different possibilities for optimizing the settings are described below.

### 4.2.1. Offset Adjustment

In contrast to a positive displacement meter, a Coriolis Mass Flow Meter does not have a “natural” zero. At no flow the measured time shift is nearly zero, but not exactly. The offset adjustment determines this offset and corrects the measured value correspondingly.

As the offset depends slightly upon the temperature, the density of the medium and the operating pressure, it is strongly recommended to make the offset procedure under working conditions, i.e. with the medium to be measured and at operating pressure and temperature.

To execute an offset adjustment, please refer to chapter 4.4 and 4.5.3.

### 4.2.2. Flow Filter

The raw data of a Mass Flow Meter is relatively noisy. To get a stable reading a filtering of the calculated flow is required.

The filters in the TCE 8000 are set by means of the time constant  $t$ . The time constant is the time the output needs, after a jump from a value  $x$  to 0, to go to  $x/e = x/2.72$ . A higher time constant means more stable reading, but also a slower reaction to changing flows.

A rough relation between the time and the filtered flow value after a jump is:

Elapsed time	Remaining Error (% of the step)
1 * $t$	30
2 * $t$	10
3 * $t$	3
4 * $t$	1



A linear filter as it is realized in the TCE 8000 electronics just delays the flow reading and consequently the "TOTAL" value. Independent of the slope (fast or slow) of the rising and falling flow, the error of the internally calculated TOTAL and at the frequency output are canceled out, if the flow rises from zero (or any other value) and later goes back to the starting value. For getting a correct "TOTAL" via the display or the frequency output, it is just necessary to wait long enough after the flow is switched off.

For best results the TCE 8000 electronics provides two filters.

The "FLOW FILTER" filters the mass flow before calculating the TOTAL or the frequency and current outputs. For normal applications a moderate filtering with  $t = 1$  s is recommended.

The "DISPLAY FILTER" filters the flow display additionally to the "FLOW FILTER". It does not affect any other parameter or any of the outputs. The default setting is  $t = 1$  s.

If the flow is changing fast or sometimes makes a jump and the outputs have to react as fast as possible, set "FLOW FILTER" to  $t < 1$  s. If nevertheless the flow display has to be stable for better readability, the "DISPLAY FILTER" can be increased.

For setting up the "FLOW FILTER" refer to chapter 4.5.7.1, for the "DISPLAY FILTER" to chapter 4.5.4.2.

### 4.2.3. CUT OFF

As mentioned above, a Mass Flow Meter has no natural zero and the raw data is noisy. Consequently, with no flow, a meter would indicate and give out continuously a small fluctuating flow.

The parameter "CUT OFF" is used to provide a clear zero. If the calculated and filtered flow is below "CUT OFF", the meter indicates zero, the "TOTAL" values remain unchanged and the outputs show zero flow as well.

The value for "CUT OFF" must be above the noise floor in the given application and well below the minimum flow to be measured. As a good compromise the default value for "CUT OFF" is 0.3 % of the full scale range of the meter.

For setting "CUT OFF" please refer to chapter 4.5.6.1.

### 4.2.4. Interaction of the Parameters

As each of the three parameters affects the calculation of the flow in a different way, a bad combination of different parameters can lead to systematical errors.

#### **FLOW FILTER and CUT OFF**

If the filter constant is set to a high value, the calculated flow is delayed compared to the actual flow. In ON/OFF operation this leads to the fact that it takes a long time until the calculated flow settles to the ON or OFF value. The "TOTAL" value remains correct if the TCM measures long enough after the flow got switched off. If "CUT OFF" is set to a high value, the meters stops measuring too early and consequently the calculated "TOTAL" is too low. Also the number of pulses at the frequency output is too low. The error is systematic.

---

#### **NOTE:**

In ON-OFF operation high values for the flow filter combined with high values for "CUT OFF" must be avoided!

Jumps of the flow not going down to zero are not affected by "CUT OFF".

---

## 4.3. Measuring Mode

### 4.3.1. Function of the Pushbuttons

In the measuring mode all pushbuttons have a fixed function:

P	Opens the Control Menu if pressed for about 2 - 3 seconds
Reset	Resets the "BATCH" counter to zero, if the function "KEY RESET" is enabled
Display	Toggles the display between the preselected settings.
Info	Opens the info menu

### 4.3.2. Display Selection

The TCE provides two presettable display views. Ex factory view 1 shows the flow and the "TOTAL" value, view 2 shows density and temperature.

In the "fixed mode" the display view selected by the user remains active until the other view is selected. For changing from one view to the other just press the pushbutton "Display".

In the "alternate mode" the TCM toggles between display view 1 and 2 every seven seconds. In this mode the pushbutton "Display" is without function.

For changing the content of the display views, please refer to chapter 4.5.4.

### 4.3.3. Display Resolution

The measured values can be displayed with 8 digits, including decimal point and sign. The most positive value therefore is "9999999." (7 digits), the most negative value is "-999999." (6 digits).

If the decimal point is set in that way that one or more decimal points are displayed and the value to be displayed exceeds the display range, the decimal point will be shifted to the right.

**Example:**

Decimal point setting:	x.xxx	x.xxx
Measured value:	12345.6789	-12345.6789
DP setting changed to:	xx.xx	xxx.x
Displayed value:	12345.67	-12345.67

The new setting for the decimal point will remain, also if the measured value goes down again. It can only be reset to the original settings in the "DISPLAY" menu.

If the decimal point is at the most right position and the measured or calculated value is still too big for being displayed, the display shows "DISPLAY OVERFLOW". As soon as the measured value returns into the displayable range, the error message disappears and the display shows the value.

If the display shows "DISPLAY OVERFLOW", change the engineering units. If any "TOTAL" display shows "DISPLAY OVERFLOW", you can also reset the "TOTAL" values. (see chapter 4.5.10).

### 4.3.4. Resetting the Batch (TOTAL-) Value

For easy batching in local operation the TCE provides the possibility to reset the Batch value by pressing the pushbutton "Reset". For protecting the TRICOR CLASSIC Mass Flow Meter against unintentional resetting, this function can be disabled.

For changing the setting, please refer to chapter 4.5.6.2.



## 4.3.5. Event Logging

Starting with software version Mv3.40 and Dv3.40, all TRICOR CLASSIC mass flow meters include event logging that records events occurring at runtime with a timestamp and a unique code. These events can either be shown on the display or read/reset (erased) via Modbus. The use of event logging is explained below using the display as an example. For a description of access via Modbus, see the TRICOR CLASSIC Modbus manual (document: “Modbus (RTU) Manual”: chapter 3.6).

There are three event classes:

- INFO: Information that a permissible event has occurred (successful initialisation for example).
- WARN: Warning that a generally permissible but possibly problematic event has occurred
- ERR:ON or ERR:OFF: Indicates that an error state has occurred (ERR:ON) or is no longer active (ERR:OFF)

### 4.3.5.1. Event codes

All events codes are listed below and their meanings are explained.

#### Error (ERR codes)

Event Code		Message on display	Meaning
ERR: ON	ERR: OFF		
0	96	INITIALIZATION FAILED	Device initialisation could not be completed successfully.
1	97	AMP. SENSOR A	The voltage amplitude induced from Sensor A is too high or too low.
2	98	AMP. SENSOR B	The voltage amplitude induced from Sensor B is too high or too low.
3	99	MEAS. DELAY OVER 250	The measured time delay is above the specified allowable limit value
5	101	UNST. DRIVER CURRENT	Driver current is too unstable
6	102	PT1000 OUT OF RANGE	The value of the temperature sensor is too high or too low (often indicates a line break or short circuit)
7	103	TUBE FREQ. TOO LOW	The frequency of the oscillating tube is below the specified allowable limit value
8	104	TUBE FREQ. TOO HIGH	The frequency of the oscillating tube is above the specified allowable limit value
9	105	DRIVER CURRENT LOW	The driver current is below the specified allowable limit value
10	106	DRIVER CURRENT HIGH	The driver current is above the specified allowable limit value
17	113	MASS FLOW TOO HIGH	The mass flow is above the specified allowable limit value
18	114	MASS FLOW TOO LOW	The mass flow is below the specified allowable limit value
19	115	TEMPERATURE TOO HIGH	The temperature is above the specified allowable limit value
20	116	TEMPERATURE TOO LOW	The temperature is below the specified allowable limit value
21	117	DENSITY TOO HIGH	The density is above the specified allowable limit value
22	118	DENSITY TOO LOW	The density is below the specified allowable limit value

Event Code		Message on display	Meaning
ERR: ON	ERR: OFF		
23	119	PRESSURE TOO HIGH	The pressure is above the specified allowable limit value
24	120	PRESSURE TOO LOW	The pressure is below the specified allowable limit value

Tab. 1: List of errors (ERR Codes)

### Warnings (WARN Codes)

Event code WARN	Message on display	Meaning
192	FACT. BACKUP MISSING	A factory backup has not been prepared yet
193	BACKUP NOT UP TO DATE	Settings have been changed but not yet saved in the backup
194	OFFSET IN PROGRESS	Zero point adjustment is currently in progress
195	GRAND TOTAL VOL OVFL	Overflow of the Grand Total on the display in modus: volume measurement. After this overflow the representation of the total in the display will automatically switch to scientific (exponential) notation
196	GRAND TOTAL MASS OVFL	Overflow of the Grand Total on the display in modus: mass measurement. After this overflow the representation of the total in the display will automatically switch to scientific (exponential) notation
197	BATCH TOTAL VOL OVFL	Overflow of the Batch Total on the display in modus: volume measurement. After this overflow the representation of the total in the display will automatically switch to scientific (exponential) notation
198	BATCH TOTAL MASS OVFL	Overflow of the Batch Total on the display in modus: mass measurement. After this overflow the representation of the total in the display will automatically switch to scientific (exponential) notation
199	FAIL. TOTAL VOL OVFL	Overflow of the Failure Total on the display in modus: volume measurement. After this overflow the representation of the total in the display will automatically switch to scientific (exponential) notation
200	FAIL. TOTAL MASS OVFL	Overflow of the Failure Total on the display in modus: mass measurement. After this overflow the representation of the total in the display will automatically switch to scientific (exponential) notation
192	FACT. BACKUP MISSING	A factory backup has not been prepared yet
193	BACKUP NOT UP TO DATE	Settings have been changed but not yet saved in the backup
194	OFFSET IN PROGRESS	Zero point adjustment is currently in progress

Tab. 2: List of warnings (WARN Codes)



## Information (INFO Codes)

Event code INFO	Message on display	Meaning
224	FACT. BACKUP OK	A factory backup has been prepared
225	BACKUP IS UP TO DATE	All new settings have been saved in the backup
226	POWER ON SEQUENCE	The device has been powered up
227	INITIALIZATION PASSED	Device initialisation was completed successfully

Tab. 3: List of information (INFO Codes)

### 4.3.5.2. Info and event log menu

The TCE display has an info and event log menu for straightforward troubleshooting. The contents of this menu are not of interest for normal operation. It only contains information for trained personnel.

To open the menu, press the “Info” button for about three seconds. Then the event log menu (“LOG DISPLAY”) is displayed first. All recorded log entries are shown and can be reset (erased) here.

### Display of log entries

“NO LOGS” is displayed if no events have been recorded or they have all been reset:

```
** LOG DISPLAY **  
NO LOGS
```

If events have been recorded, the most recent entry is always displayed first (the logged events are displayed in the order in which they occurred).

This is illustrated here with two log entries as an example:

```
** LOG DISPLAY **  
LOG#: 2/2 INFO  
TIMESTAMP: 4,800s  
INITIALIZATION PASSED
```

Here the most recently recorded (most current) is an INFO event that is the second of a total of two existing log entries. It was recorded approximately 4.8 seconds after powering up the TCE and provides the information that initialisation of the TCE was completed successfully at that time (“INITIALIZATION PASSED”).



### Resetting (erasing) event logs

Press the “Reset” button to reset (erase) the current log entry.

Provided the displayed event does not represent an active error state (“ERR:ON”), the following dialogue is displayed where you can confirm resetting the log entry by pressing the “Display” button or cancel by pressing the “Reset” button (attention: log entries cannot be restored once they have been reset):

```

**   LOG DISPLAY   **
      LOG#: 2/2 INFO
      CLEAR THIS LOG ENTRY?
      YES                NO
    
```

If the displayed log entry is of the type “ERR:ON”, it cannot be reset as long as the corresponding error state remains active. In this case the following warning is shown on the display when the “Reset” button is pressed:

```

**   LOG DISPLAY   **
      LOG#: 3/4 ERR:ON
      LOG CANNOT BE CLEARED
      ERROR IS STILL ACTIVE
    
```

If you want to reset all log entries at once, you can do so in the setup menu under the menu item “CLEAR LOGS” (see chapter 4.5.11).

### Navigating between log entries

Press the “Display” button to show the previous event (log entry) in chronological order:

```

**   LOG DISPLAY   **
      LOG#: 1/2 INFO
      TIMESTAMP: 0,005s
      POWER ON SEQUENCE
    
```

Press the “Info” button to navigate to the previous log entry. You can repeat this until you get to the last log entry.

### Info menu

When the last log entry is displayed (for instance LOG#: 5/5 INFO), pressing the “Info” button again opens the Info menu that lists the following 7 internal device parameters:

Code	Value
SA	Sensor voltage A in mV
SB	Sensor voltage B in mV
DR	Drive current in mA
PT	Resistance value of the temperature sensor in Ω
FRE	Oscillating frequency in Hz
ZP	Zero point offset in μs
TSF	Filtered time shift in μs

Tab. 4: List of service parameters



Press “Info” again to get general information about the TCM:

Code	Value
TYPE:	Sensor type (TCM*)
SER.:	Serial number
SW1:	SW version main board
SW2:	SW version display
COMM:	Active interface: Modbus/baud rate/address HART®/address FF/address
CODE:	SW option code

Tab. 5: List of TCM device info

By pressing “Info” you can toggle between those info views. To return to the normal operation screen, press “DISPLAY”.

## 4.3.6. Totalizer

On the display the following three totalizer can be shown:

- Batch Total
- Grand Total
- Failure Total

The maximum number of places that can be shown on the display is limited to 7 („1234567”).

If a totalizer exceeds this limit, the representation of the total on the display will automatically switch to scientific (exponential) notation.

For example, if a totalizer has the value „9999999” kg and then get incremented by another one kilogram, the totalizer will now display: „1.0000E7” kg.

Thus ensures that no totalizer can be resetted by an overflow in the lifecycle of the device.

## 4.4. Offset Adjustment

For best accuracy the TRICOR CLASSIC Mass Flow Meter needs an in situ offset adjustment. This calibration zeroes out the ambient effects and increases the measuring accuracy at low flow.

The offset adjustment must be carried out with the medium to be measured and at a temperature and pressure as close to the normal operation as possible.

**Proceed as follows:**

Operate the TCM for a while under normal operating conditions to make sure that the actual temperature of the TRICOR CLASSIC Mass Flow Meter equals the normal operating temperature.

Switch off the flow. For best results use a valve in front and one behind the TCM. If the valves are not close to the TCM and/or only one valve is used, wait long enough to be sure that there is no more flow through the TCM.

---

**NOTE:**

If there is a residual flow through the TCM or it is exposed to mechanical shocks during the offset adjustment procedure, the resulting value will be wrong.

---

Start the offset procedure as follows (see also chapter 4.5.3):

- Press “P” for about three seconds
- The display shows “ZERO OFFSET”
- Press “P”
- Change the indicated number with “UP” to “2207” and confirm with “P”
- Press “SLOW” (recommended) or “FAST”
- The display shows “MAKE ZERO” for 10 to 30 seconds and counts down to “0”
- Confirm with “Info”

Depending on the meter size and the density of the medium, the offset procedure takes about 10 -20 seconds (FAST) or 30...60 seconds (SLOW). During this procedure the red LED will flash.

For an automatic offset adjustment initiated by the central control unit, the control input can be configured as “Initiate offset”. In that case the TCE starts an offset procedure each time a high level is applied to the input.

To configure the input, please refer to chapter 4.5.8.4.

## 4.5. Control Mode

In the control mode the TCE 8000 can be adapted to the individual application. As unintentional changes of the settings might cause problems, some submenus are password protected. Additionally, using the “SERVICE” menu, a global access code can be set that locks the TRICOR CLASSIC Coriolis Mass Flow Meter completely.

To enter the control mode proceed as follows:

Press “P” for about three seconds



If a global access code is set the display shows

```
ENTER P-ACCESS CODE
0000
LEFT   UP   EXIT
```

Change the indicated number with “LEFT” and “UP” to the defined code and confirm with “P”.

If a wrong code is entered, the display shows “ERROR” for about two seconds and then returns to the measurement mode.

When the correct code is entered the display shows

```
MAIN MENU
ZERO OFFSET
UP   DOWN   EXIT
```

With the keys “UP” and “DOWN” you can scroll through the main list.

Select the desired submenu and confirm with “P”.

---

**NOTE:**

With the “Custody Transfer” option, no settings can be configured when the housing is closed since the P button is deactivated.

---

## 4.5.1. Function of the Pushbuttons

In the setup menu some pushbuttons have changing functions, indicated in the display above the pushbutton:

P	Confirms the selection in a list or any kind of inputs
Reset	Performs the indicated function
Display	Performs the indicated function.
Info (Exit)	Performs the indicated function. In most cases exits the current menu point without altering the original value

## 4.5.2. Submenus in the Main Menu

In the Main Menu the following submenus are addressable:

**ZERO OFFSET:**

Performing the automatic offset adjustment procedure.

This submenu is password protected.

**DISPLAY:**

Presetting the display.

Changes made in this submenu have no influence on the general function as well on the accuracy of the TCM.

**SETUP:**

Adjusting the TCE 8000 and configuring the inputs and outputs.

This submenu is password protected.

**I/O-TEST:**

Setting the outputs to defined values and displaying the actual status of the control inputs for testing the electrical connections.

This submenu is password protected.

**SERVICE:**

Calibrating the TCE 8000 with connected TCM.

This submenu is password protected.

**FACTORY:**

Service settings for TCE 8000 with connected TCM.

This submenu is password protected.



## 4.5.3. ZERO OFFSET Menu

Select in the main menu

```
MAIN MENU
ZERO OFFSET
UP    DOWN    EXIT
```

Press "P". The display shows

```
ENTER MENU CODE !
2206
LEFT  UP      EXIT
```

Change the indicated number with "LEFT" and "UP" to "2207" and confirm with "P".

If a wrong code is entered, the display shows "ERROR" for about two seconds and then asks for a new input.

When the correct code is entered the display shows

```
START OFFSET
PROCEDURE
SLOW  FAST  EXIT
```

Press "SLOW" or "FAST" to start the procedure or skip with "EXIT".

A "SLOW" procedure lasts 30 s to 60 s, a "FAST" procedure 10 s to 20 s.

The display shows

```
MAKE ZERO (s): 9.5
OLD ZERO:      0.000 µs
NEW ZERO:      µs
```

The time counter counts down to zero. The display shows e.g.

```
MAKE ZERO (s): 0.0
OLD ZERO:      0.000 µs
NEW ZERO:      0.123 µs
EXIT
```

Press "EXIT" to return to the measuring mode.

## 4.5.4. DISPLAY Menu

Select in the main menu

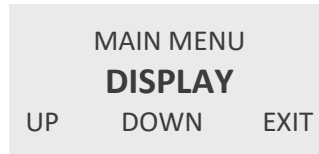

Press “P”. The display shows

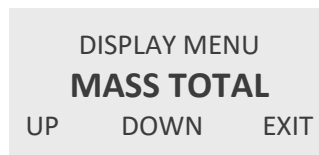

The following submenus are available:

**MASS TOTAL:**

Setting the mass TOTAL and Batch units and the mass TOTAL and Batch decimal point.

**MASS FLOW:**

Setting the mass flow units, the mass flow decimal point and a flow filter for the display.

**TEMPERATURE:**

Setting the temperature units and the temperature decimal point.

**PRESSURE:**

Setting the pressure units (only available with option “PRESSURE COMPENSATION”).

**DISP MODE:**

Setting the content of the two display views and the display mode (static or alternating).

### 4.5.4.1. DISPLAY - MASS TOTAL Menu

In the submenu “MASS TOTAL” the mass “TOTAL” and Batch engineering units and the flow decimal point can be set.

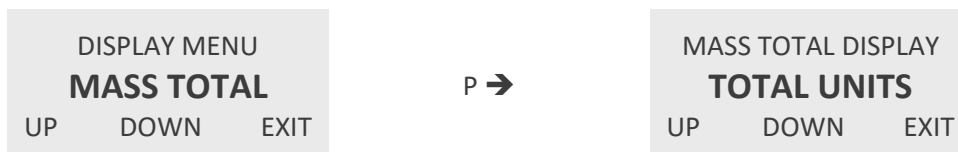

Use the keys “UP” and “DOWN” to select the desired submenu and confirm with “P” or skip with “EXIT”.



The following submenus are available:

**TOTAL UNITS:**

Setting the “TOTAL” units.

**TOTAL DP:**

Setting the “TOTAL” decimal point.

**TOTAL UNITS**



The following units can be selected:

Mass-Unit	Description
GRAM	gram
KG	kilogram
POUNDS	pound
OUNCES	dry ounce
TONS	metric ton
STONES	stone
MT	metric ton

Use the keys “UP” and “DOWN” to select the engineering unit and confirm with “P” or skip with “EXIT”.

**TOTAL DP**



Use the key “LEFT” to select the desired decimal point position and confirm with “P” or skip with “EXIT”.

#### 4.5.4.2. DISPLAY - MASS FLOW Menu

In the submenu “MASS FLOW” the mass flow engineering unit, the flow decimal point and the flow filter for the display can be set.



Use the keys “UP” and “DOWN” to select the submenu and confirm with “P” or skip with “EXIT”.

The following submenus are available:

**FLOW UNITS:**

Setting the flow units.

**FLOW DP:**

Setting the flow decimal point.

**DISP FILTER:**

Setting the display filter.



### FLOW UNITS



The following units (mass per time) can be selected:

Time-Unit	Description
S	second
MIN	minute
H	hour
D	day

Mass-Unit	Description
G	gram
KG	kilogram
LB	pound
OZ	dry ounce
T	metric ton
ST	stone
MT	metric ton

Use the keys “UP” and “DOWN” to select the engineering unit and confirm with “P” or skip with “EXIT”.

### FLOW DP



Use the key “LEFT” to select the desired decimal point position and confirm with “P” or skip with “EXIT”.

### DISP FILTER



The time constant  $t$  is the time the displayed value needs after a jump from a value  $x$  to 0 to go to  $x/e = x/2.72$ .

#### NOTE:

The display filter only filters the value in the display to provide a more stable reading. It has no influence on the outputs. It is only valid for the mass or volume flow display view!

As the display filter is additional to the global filter, the display can never react faster than the outputs.

Use the keys “RIGHT” and “UP” to select the desired time constant and confirm with “P” or skip with “EXIT”.



## 4.5.4.3. DISPLAY - TEMPERATURE Menu

In the submenu “TEMPERATURE” the temperature unit and the temperature decimal point for the display can be set.



Use the keys “UP” and “DOWN” to select the submenu and confirm with “P” or skip with “EXIT”.

The following submenus are available:

### TEMP UNITS:

Setting the temperature units.

### TEMP DP:

Setting the temperature decimal point.

### TEMP UNITS



The following units can be selected:

Unit	Description
°C	Centigrade
°F	Fahrenheit
KELVIN	Kelvin

Use the keys “UP” and “DOWN” to select the engineering unit and confirm with “P” or skip with “EXIT”.

### TEMP DP



Use the key “LEFT” to select the desired decimal point position and confirm with “P” or skip with “EXIT”.

#### 4.5.4.4. DISPLAY - PRESSURE Menu

In the submenu “PRESSURE” the pressure engineering unit and the decimal point can be set.

**NOTE:**

This menu is only visible with the option “PRESSURE COMPENSATION”.



Use the keys “UP” and “DOWN” to select the desired submenu and confirm with “P” or skip with “EXIT”.

The following submenus are available:

**PRESS. UNITS:**

Setting the pressure units.

**PRESSURE DP:**

Setting the pressure decimal point.

**PRESS. UNITS**



The following units can be selected:

Unit	Description
KPA	kilopascal
MPA	megapascal or N/mm <sup>2</sup>
PSI	pound per square inch
BAR	bar

Use the keys “UP” and “DOWN” to select the engineering unit and confirm with “P” or skip with “EXIT”.

**PRESS DP**



Use the key “LEFT” to select the desired decimal point position and confirm with “P” or skip with “EXIT”.



## 4.5.4.5. DISPLAY - DISPLAY MODE Menu

In the submenu “DISP MODE” the display mode can be set.



Use the keys “UP” and “DOWN” to select the desired submenu and confirm with “P” or skip with “EXIT”.

The following submenus are available:

### DISPLAY 1:

Setting the content of display view 1.

### DISPLAY 2:

Setting the content of display view 2.

### BACKLIGHT:

Switching on and off the backlight.

### TIME MODE:

Setting fixed or alternating display.

### DISPLAY 1



Use the keys “UP” and “DOWN” to select dual line or single line and confirm with “P” or skip with “EXIT”.

The display shows:

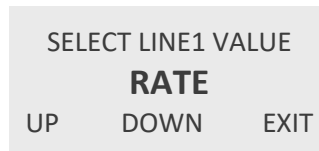

The following values can be selected:

Value	Description
RATE	Actual flow
BATCH TOTAL	Batch count
TEMPERATURE	Temperature
GRAND TOTAL	TOTAL count
FAIL. TOTAL	Failure total count
F-OUT	Actual frequency at the frequency output
mA-OUT I1	Actual current at the analog output 1
mA-OUT I2	Actual current at the analog output 2
mA-IN	Actual current at the analog input (optional)
PRESS ext.	Pressure value measured from the actual analog input current (optional)
comp PRESS	Pressure value used for compensation (optional)

Use the keys “UP” and “DOWN” to select the desired value and confirm with “P” or skip with “EXIT”.

If “DUAL LINE” was selected, the display shows

```

SELECT LINE2 VALUE
BATCH TOTAL
UP   DOWN   EXIT
    
```

Use the keys “UP” and “DOWN” to select the desired value and confirm with “P” or skip with “EXIT”.

The TCM returns to the “DISPLAY MODE” menu.

**DISPLAY 2**

See DISPLAY 1

**BACKLIGHT**

```

SET DISPLAY MODE
BACKLIGHT
UP   DOWN   EXIT
    
```

P →

```

SET BACKLIGHT MODE
ON
UP   DOWN   EXIT
    
```

Use the keys “UP” and “DOWN” to switch on or off the backlight and confirm with “P” or skip with “EXIT”.

**TIME MODE**

```

SET DISPLAY MODE
TIME MODUS
UP   DOWN   EXIT
    
```

P →

```

SET TIME MODE
FIXED
UP   DOWN   EXIT
    
```

In the “FIXED” mode the display shows constantly the defined display view 1 or 2. With the pushbutton “DISPLAY” it is possible to switch over between display view 1 or 2.

In the “ALTERNATE” mode the display switches over every 7 seconds between display view 1 and 2. The pushbutton “DISPLAY” is deactivated.

Use the keys “UP” and “DOWN” to select the desired mode and confirm with “P” or skip with “EXIT”.

### 4.5.5. SETUP Menu

In the “SETUP” menu all settings can be made to adapt the meter to the individual requirements.

Select in the main menu

```

MAIN MENU
SETUP
UP   DOWN   EXIT
    
```

Press “P”. The display shows

```

ENTER CODE
2206
LEFT  UP   EXIT
    
```

Change the indicated number with “LEFT” and “UP” to “2207” and confirm with “P”. If a wrong code is entered, the display shows “ERROR” for about two seconds and then asks for a new input.



When the correct code is entered the display shows



The following submenus are available:

**PARAMETER:**

- CUT OFF                      Setting the flow CUT OFF value
- RESET KEY                    Enable/disable the key "Reset"
- FLOW-DIREC                 Setting up the TCM for reverse flow
- K-FACTOR                    Factor for fine scaling the metric variable of the meter
- FAULT TIME                 Setting the error response time
- PRESS. COMP.              Enable/disable the "PRESSURE COMPENSATION" (option)
- TOTAL COUNT              Setting up the mode of operation "TOTAL counter"
- LANGUAGE                  Selecting the display language

**FILTER:**

- FLOW                         Setting the flow filter time constant

**IN/OUTPUTS:**

- FREQ OUT                    Configuring the frequency output
- CTRL OUT                    Configuring the control output
- mA OUT                      Configuring the analog output (4 ... 20 mA)
- CTRL IN                     Configuring the control input
- mA-IN I1                    Configuring the analog input (option)
- INTERFACE                 Configuring the interface

**DATA CONFIG:**

- SAVE DATA                 Saving the actual settings as backup
- RECALL DATA              Recalling the last settings from the backup

**RESET TOTAL:**

- RESET TOTAL                Resets the TOTAL and the FAIL. TOTAL count to zero.

**CLEAR LOGS:**

- CLEAR LOGS                Acknowledge (delete) all logged events in the Log memory.

Use the keys "UP" and "DOWN" to select the desired submenu and confirm with "P" or skip with "EXIT".

## 4.5.6. SETUP - PARAMETER Menu

In the submenu "SETUP - PARAMETER" all user settable internal parameter can be set for adjusting the TCM for a given application.



Use the keys "UP" and "DOWN" to select the desired submenu and confirm with "P" or skip with "EXIT".

#### 4.5.6.1. CUT OFF Menu

In the submenu CUT OFF the CUT OFF value in percent of the full scale flow range can be set.

If the absolute value of the measured and filtered flow is below the CUT OFF value, the calculated flow is zero and consequently all outputs show zero flow and the TOTAL and batch value remain unchanged.

Typical values for CUT OFF are in the range 0.3...1%. With CUT OFF values set too low noise or any external interference might be misinterpreted as real flow. Using too high CUT OFF values, low flows might not be correctly registered anymore.

The preset CUT OFF should always be significantly smaller than the lowest flow to be measured.



Select the submenu FLOW and confirm with “P” or skip with “EXIT”.



Use the keys “RIGHT” and “UP” to select the desired value and confirm with “P” or skip with “EXIT”.

The display returns to the “CUT OFF” menu.

#### DENSITY Gas

In case there is no presetting ex factory, make sure to change DENSITY CUT OFF to 0.0 [units].



Use the keys “RIGHT” and “UP” to select the desired value and confirm with “P” or skip with “EXIT”.

The display returns to the “CUT OFF” menu.

#### 4.5.6.2. RESET KEY Menu

In the submenu “RESET KEY” the pushbutton “Reset” can be enabled or disabled.

If the pushbutton “Reset” is active, it can be used to reset the batch counter.



Use the keys “UP” and “DOWN” to enable or disable the key and confirm with “P” or skip with “EXIT”.

The display returns to the “SETUP - PARAMETER” menu.



## 4.5.6.3. FLOW DIRECTION Menu

In the submenu “FLOW-DIREC” the positive direction of the flow can be set.

If the flow direction is set to “FORWARD” (default setting), a flow through the meter in direction of the arrow, indicated on the type label of the meter, will be displayed positive and the opposite flow negative.

If for technical reasons the meter must be mounted in that way, that the normal flow is against the direction of the arrow, the sign of the flow can be inverted by setting flow direction to “REVERSE”.



Use the keys “UP” and “DOWN” to select the positive flow direction and confirm with “P” or skip with “EXIT”.

The display returns to the “SETUP - PARAMETER” menu.

## 4.5.6.4. K-FACTOR Menu

In the submenu “K-FACTOR” the K-factor for the fine tuning of the flow calculation can be set.

Ex works the TRICOR CLASSIC Mass Flow Meter is calibrated with a K-factor  $k = 1.0000$ . If for any reasons the flow measured by the Mass Flow Meter differs slightly from a flow measured with other means, the value calculated by the TCM can be adjusted by changing the K-factor without the need to perform a new flow calibration.



Use the keys “RIGHT” and “UP” to select the desired value and confirm with “P” or skip with “EXIT”.

The display returns to the “SETUP - PARAMETER” menu.

## 4.5.6.5. FAULT TIME Menu

In the submenu “FAULT TIME” the reaction time of the TCE 8000 in case of an error can be defined.

The “FAULT ON DELAY TIME” is the time an error must be present, before the red LED lights up and the error output signal is activated.

The “FAULT OFF DELAY TIME” is the time an error signal persists on the red LED and on the control output, after the error disappeared.

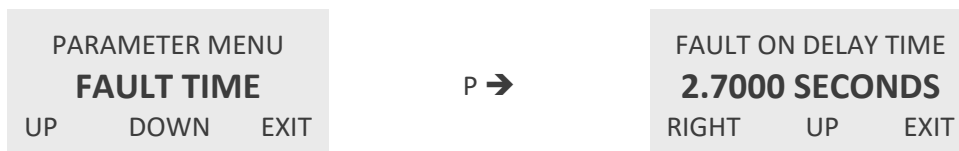

Use the keys “RIGHT” and “UP” to select the desired value and confirm with “P” or skip with “EXIT”.



The display shows

```

FAULT OFF DELAY TIME
2.7000 SECONDS
RIGHT   UP   EXIT
    
```

Use the keys “RIGHT” and “UP” to select the desired value and confirm with “P” or skip with “EXIT”.

The display returns to the “SETUP - PARAMETER” menu.

#### 4.5.6.6. PRESSURE COMPENSATION Menu

In the submenu “PRESS. COMP” the operational mode of the “PRESSURE COMPENSATION” (option) can be set.

---

#### **NOTE:**

This menu is only visible with the option “PRESSURE COMPENSATION”.

---

The following modes are possible:

#### **OFF:**

No pressure compensation.

#### **mA-IN I1:**

The pressure measured via the analog 4 ... 20 mA input is used for the compensation.

#### **MANUAL:**

The pressure set manually or via the interface is used for the compensation.

```

PARAMETER MENU
PRESS. COMP.
UP   DOWN   EXIT
    
```

P →

```

SELECT P COMP MODUS
OFF
UP   DOWN   EXIT
    
```

Use the keys “UP” and “DOWN” to select the desired mode and confirm with “P” or skip with “EXIT”.

If “mA-IN I1” selected but the status of the analog input is “OFF”, the display shows

```

CHANGE mA-IN I2
TO PRESSURE
TO PROCEED
OK
    
```

Confirm with “OK”. Configure the analog input correspondingly (see chapter 4.5.8.5) and repeat the setting.

If “MANUAL” is selected, the display shows

```

MANUAL PRESSURE RATE
0. 000 BAR
RIGHT   UP   EXIT
    
```

Use the keys “RIGHT” and “UP” to select the desired value and confirm with “P” or skip with “EXIT”.

The display returns to the “PRESS. COMP”. menu.



## 4.5.6.7. TOTAL COUNT Menu

In the submenu "TOTAL COUNT" the "TOTAL" counter can be configured.

The following operating modes are available:

### **DEFAULT:**

The "TOTAL" count includes flow in positive as well as in negative direction. With positive flow the TOTAL value increases, with negative flow it decreases.

### **FORWARD:**

The "TOTAL" count includes only flow in positive direction. With negative flow the TOTAL value does not change.

### **BACKWARD:**

The "TOTAL" count includes only flow in negative direction. With positive flow the TOTAL value does not change.



Use the keys "UP" and "DOWN" to select the mode and confirm with "P" or skip with "EXIT".

The display returns to the "SETUP - PARAMETER" menu.

## 4.5.6.8. LANGUAGE Menu

In the submenu "LANGUAGE" the language used in the display can be selected.

For the time being, English and Russian can be selected.



Use the keys "UP" and "DOWN" to select the language and confirm with "P" or skip with "EXIT".

The display returns to the "SETUP - PARAMETER" menu.

## 4.5.7. SETUP - FILTER Menu

In the submenu "SETUP - FILTER" the filters of TCE can be configured.



Use the keys "UP" and "DOWN" to select the desired submenu and confirm with "P" or skip with "EXIT".

#### 4.5.7.1. FLOW FILTER Menu

In the submenu “FLOW” the time constant for the flow filter can be set.

The time constant  $t$  is the time the output needs after a jump from  $x$  to 0 to go to  $x/e = x/2.72$ .

A rough relation between the time and the filtered flow value after a jump is

Elapsed time	Remaining error (% of the step)
1 * $t$	30
2 * $t$	10
3 * $t$	3
4 * $t$	1



Use the keys “RIGHT” and “UP” to select the desired value and confirm with “P” or skip with “EXIT”.

The display returns to the “SETUP - FILTER” menu.

#### 4.5.8. SETUP - IN/OUTPUTS Menu

In the submenu “SETUP - IN/OUTPUTS” the input and output ports can be configured.

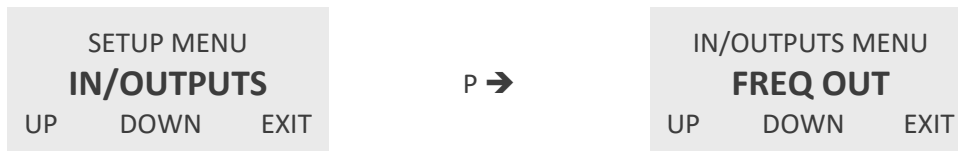

Use the keys “UP” and “DOWN” to select the desired submenu and confirm with “P” or skip with “EXIT”.

##### 4.5.8.1. FREQUENCY OUT Menu

In the submenu “FREQ OUT” the frequency output can be configured.

The frequency output has two operating modes:

**FREQUENCY:**

A frequency proportional to the actual flow is generated. If a negative flow must be given out as well, the control output can be used as sign. Frequencies between 0.5 Hz and 10 kHz can be generated in this mode.

**TOTAL COUNT:**

Each time the “TOTAL” increments by the selected “TOTAL” increment step, the output produces a pulse. For having a 50 % duty cycle, the output changes its state each time after half the increment step. If the flow is negative in between, no pulses are generated until the following positive flow compensates for the negative flow in between. Thus the medium will not be counted twice, if in between a flow backwards occurs. The maximum output frequency which can be generated in this mode is about 100 Hz.



Use the keys “UP” and “DOWN” to select the desired mode and confirm with “P” or skip with “EXIT”.

## FREQUENCY



Use the keys “RIGHT” and “UP” to select the desired full scale value and confirm with “P” or skip with “EXIT”.

The display shows

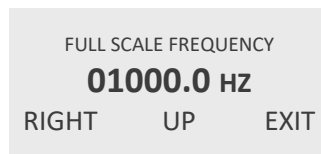

Use the keys “RIGHT” and “UP” to select the desired frequency and confirm with “P” or skip with “EXIT”.

The display shows

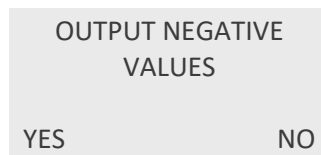

If “YES” is selected and the control output is not configured as “FLOW DIREC”, the display shows

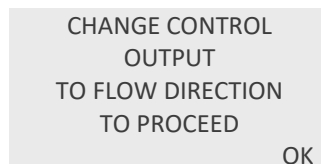

Confirm with “OK”, configure the control output correspondingly, (see chapter 4.5.8.2) and repeat the setting.

## TOTAL COUNT



Use the keys “RIGHT” and “UP” to select the desired step value and confirm with “P” or skip with “EXIT”.

#### 4.5.8.2. CONTROL OUT Menu

In the submenu “CTRL OUT” the control output can be configured.  
The control output has four operating modes:

**FAULT:**

In case of an error the control output goes to the active state.  
“ACTIVE HIGH” means the output is low in normal operation, high in case of a fault.  
For setting the on and off delay time, please refer to chapter 4.5.6.5.

**FLOW DIR:**

The flow direction is indicated. “ACTIVE HIGH” means the output is high if a positive flow is measured.

**BATCH:**

In the batch mode the TCE 8000 operates as a batch counter. If the preset batch value is reached, the control output goes to the active state. With an active signal at the control input the batch counter can be reset to zero. For this mode the control input must be configured as “RESET BATCH”. “ACTIVE HIGH” means the output goes to “HIGH” when the preset batch value is reached.

**FLOW LIMIT:**

If the actual flow becomes more positive than the “FLOW LIMIT” plus hysteresis, the output goes to the active state. If the actual flow becomes more negative than the “FLOW LIMIT” minus hysteresis, the output goes to the inactive state. Between flow limit minus hysteresis and flow limit plus hysteresis, the output state does not change.

---

**NOTE:**

For negative flow limits the relation is: -99 is greater than -100.  
“ACTIVE HIGH” means the output goes to “HIGH” when the preset limit value is reached.

---

**OFF:**

The output is deactivated. “ACTIVE HIGH” means the output is permanently at high.

**FREQUENCY:**

A frequency proportional to the current flow rate is generated. Frequencies between 0.5 Hz and 10 kHz can be generated in this mode.

**PHASE SHIFT:**

Prerequisite: the FREQ-OUT has been programmed for TOTAL COUNT. As soon as “TOTAL” has increased by the chosen amount, another pulse is generated on FREQ OUT. To have a frequency ratio of 50 % on the output, the state of the output changes respectively after half the amount. A pulse offset by 90° is also generated on CTRL OUT after each pulse on FREQ-OUT.

The maximum output frequency in this operating mode is about 50 Hz.



## FAULT



Use the keys “UP” and “DOWN” to select the desired value and confirm with “P” or skip with “EXIT”.  
The display returns to the “SETUP - IN/OUTPUTS” menu.

## FLOW DIR



Use the keys “UP” and “DOWN” to select the desired value and confirm with “P” or skip with “EXIT”.  
The display returns to the “SETUP - IN/OUTPUTS” menu.

## BATCH



Use the keys “RIGHT” and “UP” to select the desired step value and confirm with “P” or skip with “EXIT”.  
The display shows



Use the keys “UP” and “DOWN” to select the desired value and confirm with “P” or skip with “EXIT”.  
The display returns to the “SETUP - IN/OUTPUTS” menu.

## FLOW LIMIT



Use the keys “RIGHT” and “UP” to select the desired step value and confirm with “P” or skip with “EXIT”.  
The display shows



Use the keys “RIGHT” and “UP” to select the desired value and confirm with “P” or skip with “EXIT”.

The display shows

```

SELECT ACTIVE STATE
ACTIVE HIGH
UP    DOWN    EXIT
    
```

Use the keys “UP” and “DOWN” to select the desired value and confirm with “P” or skip with “EXIT”.

The display returns to the “SETUP - IN/OUTPUTS” menu.

## OFF

```

CTRL OUT MENU
OFF
UP    DOWN    EXIT
    
```

P →

```

SELECT ACTIVE STATE
ACTIVE HIGH
UP    DOWN    EXIT
    
```

Confirm with “P” or skip with “EXIT”.

The display returns to the “SETUP - IN/OUTPUTS” menu.

## FREQUENCY

```

FREQ OUT MENU
FREQUENCY
UP    DOWN    EXIT
    
```

P →

```

FULL SCALE FLOW
8000.0 G/S
RIGHT  UP    EXIT
    
```

Use the keys “RIGHT” and “UP” to select the desired full scale value and confirm with “P” or skip with “EXIT”.

The display shows

```

FULL SCALE FREQUENCY
01000.0 HZ
RIGHT  UP    EXIT
    
```

Use the keys “RIGHT” and “UP” to select the desired frequency and confirm with “P” or skip with “EXIT”.

The display returns to the “SETUP - IN/OUTPUTS” menu.

### 4.5.8.3. ANALOG OUT Menu

In the submenu “mA-OUT” the 4 ... 20 mA outputs can be configured.

Each analog output can show one of the following parameters:

#### FLOW:

The output current is proportional to the flow.

#### TEMP:

The output current is proportional to the temperature.

#### BATCH COUNT:

The output current is proportional to the current batch value.

This mode is only possible, if the control input is configured as “RESET BATCH”

The value for 4 mA as well as the value for 20 mA can be freely selected. Thus it is possible to zoom in (e.g. temperatures from 20 °C to 30 °C [68 °F up to 86 °F]) or to show negative values as well (e.g. flow from -10 kg/min to +20 kg/min).



Use the keys “UP” and “DOWN” to select the desired output channel and confirm with “P” or skip with “EXIT”.

The standard TCE electronics provides two analog 4 ... 20 mA outputs, I1 and I2. If the option “PRESSURE COMPENSATION” is installed, only the output I2 is available.

The display shows

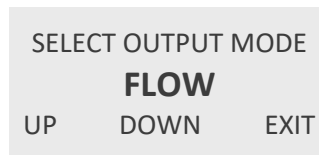

Use the keys “UP” and “DOWN” to select the desired output value and confirm with “P” or skip with “EXIT”.

The display shows

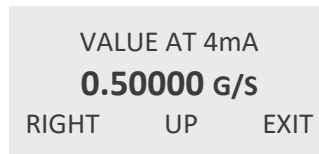

The indicated engineering unit depends on the selected output value and the display setup.

To input a negative sign (e.g. for -20 °C), move the cursor to the first digit. When the figures are incremented by pushing “UP”, the “9” is followed by the minus sign “-”, before the “0” appears.

Use the keys “RIGHT” and “UP” to select the desired value for 4 mA and confirm with “P” or skip with “EXIT”.

The display shows

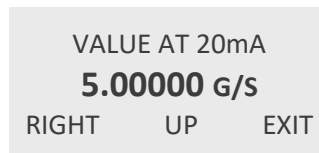

Use the keys “RIGHT” and “UP” to select the desired value for 20 mA and confirm with “P” or skip with “EXIT”.

The display returns to the “SETUP - IN/OUTPUTS” menu.

#### 4.5.8.4. CONTROL IN Menu

In the submenu “CTRL IN” the control input can be configured.

The control input has three operating modes:

##### **EXT. ZERO:**

If an “ACTIVE” level is applied to the input, the TCE 8000 starts the zero offset adjustment procedure.

##### **RESET BATCH:**

If an “ACTIVE” level is applied to the input, the batch counter is reset to 0.

This mode must be selected, if the control output is to be used as a “BATCH-LIMIT” and/or if one of the analog outputs is to be used as batch output.



## OFF:

The input is deactivated. Changes of the level applied to the input have no effect. This is the default. The "ACTIVE" level is freely selectable. Since the standard version of TCE has an internal pull-down resistor built in, the default is "ACTIVE HIGH".

## HOLD:

If an "ACTIVE" level is applied to the input, the batch and grand totals stop counting.



Use the keys "UP" and "DOWN" to select the desired mode and confirm with "P" or skip with "EXIT".

If "EXT. ZERO" or OFF is selected and one of the outputs is set to batch output, the display shows

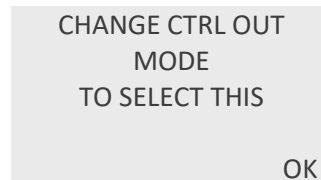

Confirm with "OK" and configure the output correspondingly if required.

The display shows



Use the keys "UP" and "DOWN" to select the desired value and confirm with "P" or skip with "EXIT".

The display returns to the "SETUP - IN/OUTPUTS" menu.

### 4.5.8.5. ANALOG IN Menu

In the submenu "mA-IN I1" the 4 ... 20 mA input can be configured. This menu is only visible with the option "PRESSURE COMPENSATION".

The value for 4 mA as well as the value for 20 mA can be freely selected to adapt the input to any passive 4 ... 20 mA pressure sensor.



Use the keys "UP" and "DOWN" to select "OFF" or "PRESSURE" and confirm with "P" or skip with "EXIT".

If "OFF" is selected, neither a pressure value is shown nor a pressure compensation using a measured pressure value is possible.



If "PRESSURE" was selected the display shows

```
VALUE AT 4mA
0.00 MPA
RIGHT  UP   EXIT
```

The indicated engineering unit depends on the selected output value and the display setup.

Use the keys "RIGHT" and "UP" to select the desired value for 4 mA and confirm with "P" or skip with "EXIT".

The display shows

```
VALUE AT 20mA
10.00 MPA
RIGHT  UP   EXIT
```

Use the keys "RIGHT" and "UP" to select the desired value for 20 mA and confirm with "P" or skip with "EXIT".

The display returns to the "SETUP - IN/OUTPUTS" menu.

#### 4.5.8.6. INTERFACE Menu

In the submenu "INTERFACE" the interface can be configured.

Depending on the configuration one or more of the following interfaces can be selected:

RS485

HART®

Foundation Fieldbus®



Use the keys "UP" and "DOWN" to select the desired mode and confirm with "P" or skip with "EXIT".

#### RS485

Data transmission is carried out via RS485 interface with the „Modbus RTU“ protocol.

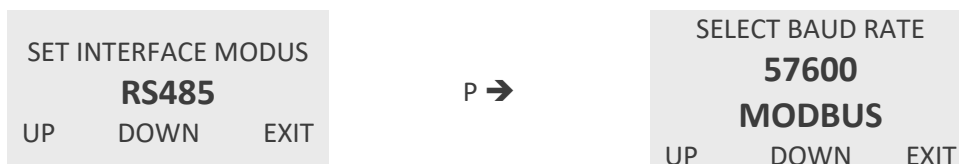

Use the keys "UP" and "DOWN" to select the baud rate and confirm with "P" or skip with "EXIT".

The display shows

```

SELECT BYTE ORDER
      3-2-1-0
RIGHT   UP   EXIT
  
```

Use the keys “UP” and “DOWN” to select the byte order for floating point numbers as it is valid with your system and confirm with “P” or skip with “EXIT”.

The display shows

```

ADDITIONAL TIME DELAY
      00800. µs
RIGHT   UP   EXIT
  
```

If the device is installed within bigger bus and controlling systems, it might be helpful to slow down additionally the response of the TCE 8000 in order to avoid any communication errors.

Use the keys “RIGHT” and “UP” to select the additional time delay and confirm with “P” or skip with “EXIT”.

The display shows

```

SET UNIT ADDRESS
      001
RIGHT   UP   EXIT
  
```

The following addresses cannot be set:

Address	Function
0	reserved for broadband communication (messages to all connected units)
248-255	reserved for special Modbus purpose

Use the keys “RIGHT” and “UP” to select the desired unit address and confirm with “P” or skip with “EXIT”.

The display returns to the “SETUP - IN/OUTPUTS” menu.

#### **HART®**

For the HART® interface special local settings are not available. All configurations are done directly via the interface.

The HART® interface is just activated and the display returns to the SETUP IN/OUTPUTS menu.

#### **Foundation Fieldbus®**

For the Foundation Fieldbus® interface special local settings are not available. All configurations are done directly via the interface.

The Foundation Fieldbus® interface is just activated and the display returns to the “SETUP - IN/OUTPUTS” menu.



## 4.5.9. SETUP - DATA CONFIGURATION Menu

In the submenu “SETUP - DATA CONFIG” the current settings can be stored to the backup memory and the stored settings can be recalled



Use the keys “UP” and “DOWN” to select the desired submenu and confirm with “P” or skip with “EXIT”.

### 4.5.9.1. SAVE DATA Menu

In the submenu “SAVE DATA” the current settings can be stored in the backup memory.

At each power on the TCE 8000 compares the content of the setup memory and the backup memory. If the data in those two memories are different, the TCE 8000 gives out a warning. To avoid this warning, it is recommended to make a backup as soon as the new settings are proven to be okay.

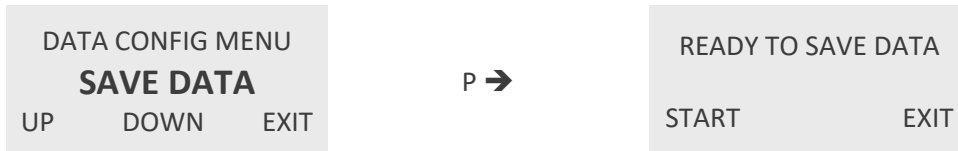

Start the backup process with “START” or skip with “EXIT”.

If “START” is pressed, the display shows for some seconds

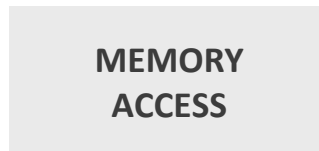

After that for about two seconds

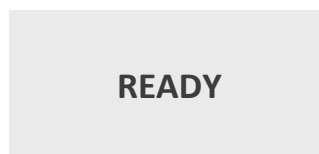

The display returns to the “SETUP - DATA CONFIG” menu.

### 4.5.9.2. RECALL DATA Menu

In the submenu “RECALL DATA” the old settings are reloaded from the backup memory.

Reloading the old settings is recommended, if after bigger changes in the setup the TCM does not work properly any more.

---

#### NOTE:

Backup data overwritten with “SAVE DATA” cannot be restored!

---



Start the recall process with “START” or skip with “EXIT”.

If “START” is pressed, the display shows for some seconds

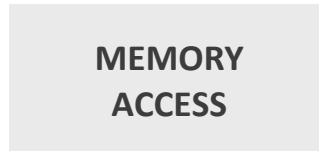

After that for about two seconds

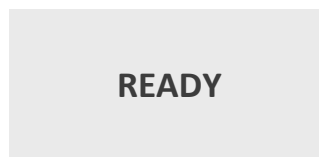

The display returns to the “SETUP - DATA CONFIG” menu.

#### 4.5.10. SETUP - RESET TOTAL Menu

In the submenu “SETUP - RESET TOTAL” the “TOTAL” counters can be reset to zero



Reset the “TOTAL” with “START” or skip with “EXIT”.

---

**NOTE:**

All TOTAL values (“GRAND TOTAL”, “BATCH TOTAL” and “FAIL. TOTAL”) are reset!

---

The display returns to the “SETUP - RESET TOTAL” menu.

#### 4.5.11. SETUP - CLEAR LOGS Menu

In the submenu SETUP - CLEAR LOGS all logged events can be acknowledged (deleted).

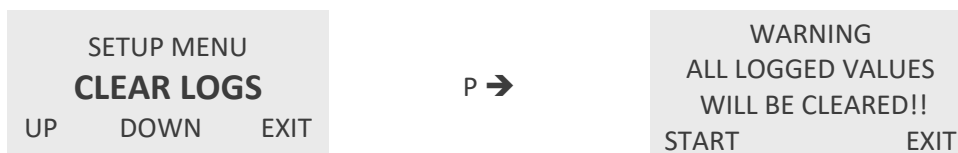

Acknowledge all logged events with „START” or skip with „EXIT” ab.

---

**NOTE:**

Acknowledged Log entries cannot be recovered.

---

Das Display kehrt zum Menü CLEAR LOGS zurück.



## 4.5.12. I/O-TEST Menu

In the "I/O-TEST" menu all inputs and outputs can be tested.

Select in the main menu

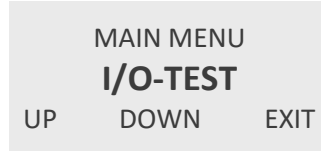

Press "P". The display shows

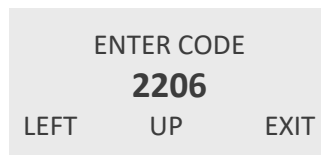

Change the indicated number with "LEFT" and "UP" to "2207" and confirm with "P".

If a wrong code is entered, the display shows "ERROR" for about two seconds and then asks for a new input.

When the correct code is entered the display shows

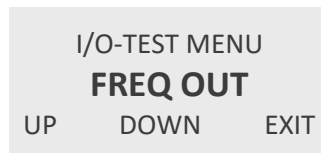

The following submenus are available:

- FREQ OUT                      A freely settable frequency can be applied to the output
- CTRL OUT                     The output level can be set
- mA-OUT                        A freely settable current can be applied to the output
- CTRL IN                        The level currently applied to the input is indicated
- mA-IN                          The current input current is indicated  
(Only with option "PRESSURE COMPENSATION")

When the "I/O-TEST" menu is left, all outputs return to normal operation.

### 4.5.12.1. I/O-TEST - FREQUENCY OUT Menu

In the submenu "FREQ OUT" a freely settable frequency, between 1 Hz and 9,999 Hz, can be applied to the output.



Use the keys "RIGHT" and "UP" to select the desired value and confirm with "P" or skip with "EXIT".

If “P” was pressed the frequency is applied to the output and the display shows

```

CHANGE VALUE?
                YES  EXIT
    
```

Press “YES” to enter a new value or “EXIT” to leave the menu.

If “EXIT” is pressed, the display returns to the “SETUP - I/O-TEST” menu.

#### 4.5.12.2. I/O-TEST - CONTROL OUT Menu

In the submenu “CTRL OUT” a low or high level can be applied to the output.

```

I/O-TEST MENU  SELECT OUTPUT
  CTRL OUT      LEVEL !
UP  DOWN  EXIT  P →  HIGH  LOW  EXIT
    
```

Use the keys “HIGH” and “LOW” to set the output value or leave the menu with “EXIT”.

If “EXIT” is pressed, the display returns to the “SETUP - I/O-TEST” menu.

#### 4.5.12.3. I/O-TEST - ANALOG OUT Menu

In the submenu “mA-OUT” a freely settable current, between 2 mA and 22 mA, can be applied to the output.

```

I/O-TEST MENU  ANALOG OUT TEST
  mA-OUT        mA-OUT I1
UP  DOWN  EXIT  P →  UP  DOWN  EXIT
    
```

Use the keys “UP” and “DOWN” to select the desired output and confirm with “P” or skip with “EXIT”.

The display shows

```

ENTER CURRENT 1 (mA)
                00.0
RIGHT  UP  EXIT
    
```

Use the keys “RIGHT” and “UP” to select the desired value and confirm with “P” or skip with “EXIT”.

If “P” was pressed the current is applied to the output and the display shows

```

CHANGE VALUE?
                YES  EXIT
    
```

Press “YES” to enter a new value or “EXIT” to leave the menu.

If “EXIT” is pressed, the display returns to the “SETUP - I/O-TEST” menu.



## 4.5.12.4. I/O-TEST - CONTROL IN Menu

In the submenu “CTRL IN” the display shows the level currently applied to the control input.



The display shows the actual level at the input. It is automatically updated when the level at the input has changed.

After evaluating the input, press “EXIT” to return to the “SETUP - I/O-TEST” menu.

## 4.5.12.5. I/O-TEST - ANALOG IN Menu (optional)

The submenu “mA-IN” is only selectable with the option “PRESSURE COMPENSATION”.

In the submenu “mA-IN” the display shows the current applied to the control input.



After evaluating the input, press “EXIT” to return to the “SETUP - I/O-TEST” menu.

## 4.5.13. SERVICE Menu

The “SERVICE” menu is used to calibrate the meter, to set a user password and to recall the original factory settings.

For a description of the menu, please refer to chapter 6.



## 5. Remote Operation

As a standard, the TCE 8000 is equipped with RS485 and HART® interfaces. Foundation Fieldbus® is also available as an option.

Please read chapter 4 before installing a remote control, for getting a description of the functionality.

### 5.1. Serial RS485 Interface

#### 5.1.1. Electrical Connection of RS485 Interface

Prepare the TCE 8000 and the cable as described in chapter 3.3.

Connect the signal RS485A or RS485+ (both names are used in the literature) to terminal 22 and RS485- or RS485B to terminal 21.

Terminal 20 is the ground reference pin for the interface and is connected to GND (terminal 8) with the non-Ex versions and connected to PE (terminal 52) with the Ex versions.

---

**NOTE:**

The operating range of the data terminals (21 and 22) is -7 V to +12 V referred to the reference pin (20). Voltages outside that range could damage the TCE 8000.

---

#### 5.1.2. Usage of the TRICOR Configurator

The control software TRICOR Configurator as well as the corresponding manual is provided for download at the “Download” area of the TRICOR webpage ([www.tricorflow.com/support/downloads/](http://www.tricorflow.com/support/downloads/)).

Using the TRICOR Configurator a remote operation with TRICOR CLASSIC meters is possible, without the need of knowledge about the Modbus protocol.

The usage of the converter CON.USB.RS-ISO is recommended for the connection between the TCE electronics and a personal computer (via USB interface).

#### 5.1.3. RS485-Interface-Protocol

For communication via RS485 the Modbus RTU protocol is used.

A detailed description of the Modbus frame structure and the implemented registers and addresses can be found at the “Download” area of the TRICOR webpage ([www.tricorflow.com/support/downloads/](http://www.tricorflow.com/support/downloads/)).



## 5.2. HART®

### 5.2.1. Electrical Connection for HART®

For the HART® communication the current output CURRENT 2 (I2) is used.

Connect the analog output CURRENT 2 as described in chapter 3.3.5 and connect a HART® communicator or a HART® Handheld Terminal in series to the analog output of the TCE.

Refer to the manual of your HART® communicator, respectively of the HART® Handheld Terminal, for the proper connection.

### 5.2.2. Device Description File for HART® Interface Protocol

For getting the newest DD file for the HART® Interface, please contact your TRICOR representative.

## 5.3. Foundation Fieldbus®

### 5.3.1. Electrical Connection for Foundation Fieldbus®

Prepare the TCE 8000 and the cable as described in chapter 3.3.2.

Connect the signal FF+ (positive rail of the bus) to terminal 32 and FF- (negative rail of the bus) to terminal 31.

### 5.3.2. Device Description File for Foundation Fieldbus® Interface Protocol

For getting the newest DD file for the Foundation Fieldbus® Interface, please contact TRICOR representative.

## 6. Service and Maintenance

### 6.1. Maintenance

The TRICOR CLASSIC Mass Flow Meters do not require regular maintenance.

In case of abrasive or sedimenting media however, it is recommended to return the measuring system to the manufacturer after 8,000 hours of operation for re-calibration and pressure test. This interval may be shorter when the medium is extremely abrasive or sedimenting. For best performance we recommend checking the calibration every 5 years, in harsh environments even more frequently.

If for the specific application an obligatory calibration is required, refer to the corresponding national regulations for the necessary calibration intervals.

### 6.2. Trouble Shooting

In case the TRICOR Mass Flow Meter does not work properly, first check the following items:

**No display, no LED lighting**

All cables properly connected?

→ Connect the missing cables

Power supply switched on?

→ Switch on the power supply

Display positioned properly (compact and wall mount only)?

→ Remove the display and reset it properly

Internal fuse of the TCE blown?

→ For checking and changing the fuses refer to chapter 6.3.

**Output frequency too high or unstable**

Most probably EMC problems

Shield and ground properly connected?

→ Connect shield properly. If necessary, try additional means of grounding and shielding

**Unstable flow reading with (theoretically) stable flow**

Gas bubbles or solid particles in the medium?

→ Mount the meter with the correct orientation

Strong external vibrations?

→ Decouple the meter from the vibration source

Flow or pressure slugs in the medium?

→ Decouple the meter hydraulically

**No frequency or current output with operating display**

Output correctly wired?

→ Correct the wiring (see chapter 2.3)

Output correctly configured?

→ Correct the configuration (see chapter 4.5.8)

Wrong flow direction (flow in the display is negative)?

→ Change flow direction (see chapter 4.5.6.3)

**Pressure display shows "PRESS ERROR"**

Input correctly wired?

→ Correct the wiring (see chapter 2.3)

Sensor working normally?

→ Check with external digital Ampere meter. If required, replace the sensor

**No pressure compensation**

Compensation enabled?

→ Enable compensation (see chapter 4.5.6.6)

Sensor working normally?

→ Check with external digital Ampere meter. If required, replace the sensor



## 6.3. Maintenance and Repair Work

---

### **WARNING!**

#### **Impermissible repair of explosion protected devices**

Risk of explosion in hazardous areas

Repair must be carried out by persons authorised by the manufacturer..

---

### **WARNING!**

#### **Maintenance during continued operation in a hazardous area**

There is a risk of explosion when carrying out repairs and maintenance on the device in a hazardous area.

Isolate the device from power. - or -

Ensure that the atmosphere is explosion-free (hot work permit).

---

### **WARNING!**

#### **Impermissible accessories and spare parts**

Risk of explosion in areas subject to explosion hazard.

Only use original accessories or original spare parts.

Observe all relevant installation and safety instructions described in the instructions for the device or enclosed with the accessory or spare part.

---

### **WARNING!**

#### **Humid environment**

Risk of electric shock.

Avoid working on the device when it is energized.

If working on an energized device is necessary, ensure that the environment is dry.

Make sure when carrying out cleaning and maintenance work that no moisture penetrates the inside of the device.

---

### **CAUTION!**

#### **Hot parts in the device**

Temperatures that can burn unprotected skin may be present for some time after the device has been switched off.

Observe the waiting time specified in "Technical Data" (see chapter 7.3) before starting with maintenance work.

---

### **WARNING!**

#### **Enclosure open**

Risk of explosion in hazardous areas as a result of hot components and/or charged capacitors inside the device.

To open the device in a hazardous area:

1. Isolate the device from power.
2. Observe the wait time specified in "Technical Data" (see chapter 7.3) before opening the device.
3. Visually inspect sensor inlet and outlet.

**Exception:** Devices exclusively having the type of protection "Intrinsic safety Ex i" may be opened in an energized state in hazardous areas.

---



---

**CAUTION!****Hazardous voltage at open device**

Risk of electric shock when the enclosure is opened or enclosure parts are removed.

Before you open the enclosure or remove enclosure parts, de-energize the device.

If maintenance measures in an energized state are necessary, observe the particular precautionary measures. Have maintenance work carried out by qualified personnel.

---

**WARNING!****Hot, toxic or corrosive process media**

Risk of injury during maintenance work.

When working on the process connection, hot, toxic or corrosive process media could be released.

As long as the device is under pressure, do not loosen process connections and do not remove any parts that are pressurized.

Before opening or removing the device ensure that process media cannot be released.

---

**WARNING!****Improper connection after maintenance**

Risk of explosion in areas subject to explosion hazard.

Connect the device correctly after maintenance.

Close the device after maintenance work.

---

The device is maintenance-free. However, a periodic inspection according to pertinent directives and regulations must be carried out.

An inspection can include check of:

- Ambient conditions
  - Seal integrity of the process connections, cable entries, and cover screws
  - Reliability of power supply, lightning protection, and grounds
- 

**NOTE:**

Repairs and service may only be carried out by persons authorised by the manufacturer.

---

**NOTE:**

The manufacturer defines flow sensors as non-repairable products.

---

**Maintenance information parameters**

The basic maintenance information parameters are:

- Current Date and Time
  - Operating Time Total
  - Operating Time
  - Configuration Counter
  - Transmitter Hardware Revision
  - HMI Hardware Revision
  - Sensor Hardware Revision
-



## 6.4. Changing the fuses

With the Ex versions the fuses are part of the safety barriers and must only be exchanged by KEM/AWL or by personnel authorized by KEM/AWL.

In case one of the fuses has blown, contact KEM/AWL or your nearest dealer.

### **WARNING!**

The Ex versions of the TCE 8000 series contain several internal fuses for protecting the intrinsically safe TCM against too high voltage and power. Those fuses are critical parts and must not be exchanged except by KEM/AWL or by service personnel authorized by KEM/AWL. If the fuses are replaced by third persons, the Ex certification for the TCM will be void!

## 6.5. Calibration

In the "SERVICE" menu all measurements of the TCE 8000 can be calibrated.

Press "P" for about three seconds

The display shows

```
MAIN MENU
ZERO OFFSET
UP   DOWN   EXIT
```

Use the key "UP" or "DOWN" to select

```
MAIN MENU
SERVICE
UP   DOWN   EXIT
```

Press "P". The display shows

```
ENTER CODE
2206
LEFT  UP    EXIT
```

Change the indicated number with "LEFT" and "UP" to "2208" and confirm with "P".

If a wrong code is entered, the display shows "ERROR" for about two seconds and then asks for a new input.

When the correct code is entered the display shows

```
SERVICE MENU
CALIBRATION
UP   DOWN   EXIT
```

Press “P”. The display shows

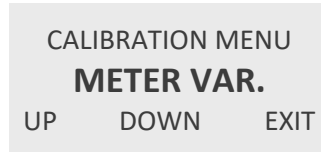

The following submenus are available:

- TEMP CALIB.                      Calibrating the temperature measurement
- METER VAR.                      Calibrating the flow measurement

### 6.5.1. Temperature Calibration

For calibrating the temperature reading of the TCE 8000, the medium temperature must be well known.

Before starting the calibration, make sure that the temperature reading has been stable for several minutes, to make sure that the medium temperature and the temperature of the temperature sensor are the same.



Use the keys “RIGHT” and “UP” to set the actual medium temperature and confirm with “P” or skip with “EXIT”.

The display returns to the “SERVICE - CALIBRATION” menu.

### 6.5.2. Flow Calibration

Mount the TCM in the test stand or mount a reference meter in series to the TCM to be calibrated. The accuracy of the test stand or reference meter must be better than 0.1 % of reading over the calibration range.

For best results with the zero offset calibration, a valve each in front and behind the TCM is recommended.

**NOTE:**

All mounting guidelines (see chapter 3) must be observed!  
 Any erroneous reading due to bad mounting will lead to a wrong calibration!

Operate the meter for at least 15 minutes for making sure that it has reached the final operating temperature. If the medium temperature differs much from the initial meter or ambient temperature, a longer warm up period might be recommended.

Close the valves and make the zero offset adjustment (see chapter 4.4 and 4.5.3).

If the calibration of the TCM shall be checked without adjusting the reading, just compare the TCM reading with the reading of the reference meter at the desired flow rates.

If the TCM shall be adjusted according to the test results, make a test run (or better several tests runs) at about 50 % of the TCM full scale flow.



Read the current TCM meter variable:



Calculate the new meter variable as:

$$METER\_VAR_{new} = METER\_VAR_{old} * \frac{Reference\ Reading}{TCE\ 8000\ Reading}$$

If you made several test runs, use the average meter variable.

Use the keys “RIGHT” and “UP” to set the calculated meter variable and confirm with “P” or skip with “EXIT”.

The display returns to the “SERVICE - CALIBRATION” menu.

## 6.5.3. Recalibration

KEM Küppers Elektromechanik GmbH and AW-Lake Company offers to recalibrate the sensor in Germany or the USA. The following calibration types are offered as standard according to configuration:

- Standard calibration
- Customer specified calibration
- Calibrations according DIN EN ISO/IEC 17025:2005
- Density calibration
- Witness calibration

## 6.6. Cleaning

### Cleaning the enclosure

- Clean the outside of the enclosure with the inscriptions and the display window using a cloth moistened with water or a mild detergent.
- Do not use any aggressive cleansing agents or solvents, e.g. acetone. Plastic parts or the painted surface could be damaged. The inscriptions could become unreadable.

## 6.7. Service

Apart from the fuses the TCE 8000 does not contain any user serviceable parts.

In case of malfunction, please contact your nearest dealer or directly KEM Küppers Elektromechanik GmbH.

For the addresses see back of the manual.

Service information is information about the condition of the device used for diagnostics and service purposes.



The basic service information parameters are:

- Driver Current
- Pickup 1 Amplitude
- Pickup 2 Amplitude
- Sensor Frequency
- Frame Temperature
- Process Media Temperature
- Zero Point Adjustment Auto/Manual
- Zero Point Offset Value
- Manual Zero Point
- Zero Point Standard Deviation

## 6.8. Global Device Password

In order to protect the TRICOR CLASSIC Mass Flow Meter from unauthorized access, a user-specific password can be set. It protects the access to all configuration menus. The password can be set either through the local display as described below or through the Modbus interface (see TRICOR CLASSIC Modbus RTU manual).

---

### NOTE:

If the global access code gets lost, the meter must be returned to KEM/AWL for resetting it. Resetting the code onsite is not possible!

---

Press “P” for about three seconds. The display shows

```
MAIN MENU
ZERO OFFSET
UP    DOWN    EXIT
```

Use the key “UP” or “DOWN” to select

```
MAIN MENU
SERVICE
UP    DOWN    EXIT
```

Press “P”. The display shows

```
ENTER CODE
2206
LEFT  UP      EXIT
```

Change the indicated number with “LEFT” and “UP” to “2208” and confirm with “P”.

If a wrong code is entered, the display shows “ERROR” for about two seconds and then asks for a new input.

When the correct code is entered the display shows

```
SERVICE MENU
CALIBRATION
UP    DOWN    EXIT
```



Use the key “UP” or “DOWN” to select ACCESS CODE and confirm with “P” or skip with “EXIT”



Change the indicated number with “LEFT” and “UP” to the desired code number and confirm with “P”.

The display shows

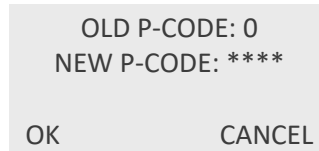

Confirm with “OK” or skip with “CANCEL”.

Write down the access code.

The display returns to the “SERVICE - ACCESS CODE” menu.

## 6.9. Reloading Factory Settings

In case the TCM has been completely misadjusted for any reason, the TCM can be reset to the original settings ex works.

Press “P” for about three seconds. The display shows

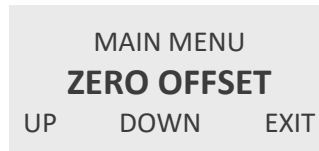

Use the key “UP” or “DOWN” to select

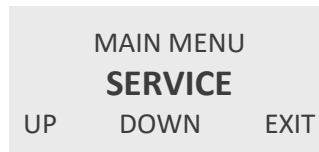

Press “P”. The display shows

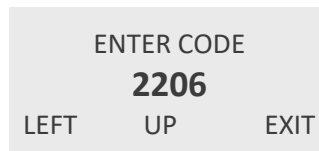

Change the indicated number with “LEFT” and “UP” to “2208” and confirm with “P”.

If a wrong code is entered, the display shows “ERROR” for about two seconds and then asks for a new input.

When the correct code is entered the display shows

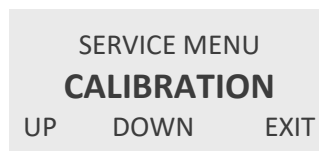

Use the key “UP” or “DOWN” to select **RECALL FACT** and confirm with “P” or skip with “EXIT”.

The display shows



Start the recall process with “START” or skip with “EXIT”.

If “START” is pressed, the display shows for some seconds

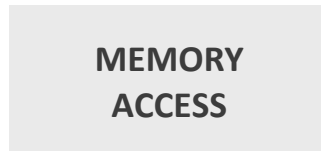

After that for about two seconds

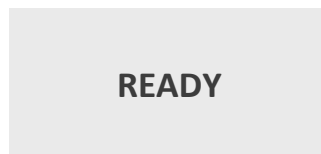

The display returns to the “RECALL FACTORY” menu.

## 7. Listings

### 7.1. Warranty

For warranty refer to the general terms and conditions of KEM Küppers Elektromechanik GmbH, which can be found on the corresponding website ([www.kem-kueppers.com](http://www.kem-kueppers.com)), respectively for the Americas those of AW Lake Company ([www.aw-lake.com](http://www.aw-lake.com)).

### 7.2. Certifications and Compliances

Category	Standards or description	
EU Declaration of Conformity - EMC	Meets intent of Directive 2014/30/EU for Electromagnetic Compatibility. Compliance is given to the following specifications as listed in the Official Journal of the European Union:	
	EN 61326/2006	EMC requirements for Class A electrical equipment for measurement, control and laboratory use, including Class A radiated and Conducted Emissions <sup>5)</sup> and Immunity <sup>5)</sup> .
	IEC 61000-4-2/2009	Electrostatic Discharge Immunity (Performance criterion B)
	IEC 61000-4-3/2011	Radiated RF Electromagnetic Field Immunity (Performance criterion B)
	IEC 61000-4-4/A1-2013	Electrical Fast Transient/Burst Immunity (Performance criterion B)
	IEC 61000-4-5/2015 <sup>6)</sup>	Power Line Surge Immunity (Performance criterion B)
	IEC 61000-4-6/2014	Conducted RF Immunity (Performance criterion B)
	IEC 61000-4-11/2005 <sup>6)</sup>	Voltage Dips and Interruptions Immunity (Performance criterion B)
Australia/New Zealand Declaration of Conformity- EMC	Complies with the EMC Emission standard <sup>5)</sup>	
	AS/NZS 2064	
FCC EMC Compliance	Emissions comply with the Class A Limits of FCC Code of Federal Regulations 47, Part 15, Subpart B <sup>5)</sup> .	

<sup>5)</sup> Compliance demonstrated using high-quality shielded interface cables.

<sup>6)</sup> Applies only to units with AC mains supply instead of or additional to the SELV supply.

Category	Standards or description	
EU Declaration of Conformity – Low Voltage	Compliance is given to the following specification as listed in the Official Journal of the European Union: Low Voltage Directive 2014/35/EU	
	EN 61010-1/2010	Safety requirements for electrical equipment for measurement control and laboratory use.
Designed to meet the following US standards	UL 61010-1/2012	Standard for electrical measuring and test equipment.
Designed to meet the following Canadian standards	CAN/CSA C22.2 no. 61010-1-4/2008	Safety requirements for electrical equipment for measurement, control, and laboratory use.
International standards	IEC61010-1/2010	Safety requirements for electrical equipment for measurement, control, and laboratory use.
Equipment Type	Test and measuring	
Safety Class	Class 1 (as defined in IEC 61010-1, Annex H) – grounded product	
ATEX Zone 1 IECEX	II 2(1)G Ex db [ia Ga] IIC T4 Gb	TCE 800*-W-****-Ex and TCE 800*-W-****-Ex3
	II 1G Ex ia IIC T4...T2 Ga	TCM 0450-*_*_*_*_*_*_*_*_*_*-Ex and TCM 0450-*_*_*_*_*_*_*_*_*_*-Ex3
ATEX Zone 2	II 3G Ex nA IIC T4	TCE 800*-W-****-Exn
	II 3G Ex nA IIC T4	TCM 0450-*_*_*_*_*_*_*_*_*_*-Exn
cCSAus	Cl. 1, Div. 1, Group A-D: T4 (US, Can) Ex db [ia Ga] IIC T4 Gb (Can)	TCE 800*-W-****-Ex1 and TCE 800*-W-****-Ex3
	Cl. 1, Div. 1, Group A-D: T4...T2 (US, Can) Ex ia IIC T4...T2 Ga (Can)	TCM 0450-*_*_*_*_*_*_*_*_*_*-Ex1 and TCM 0450-*_*_*_*_*_*_*_*_*_*-Ex3
EAC (TR-CU)	1Ex d [ia] IIC T4 Gb X	TCE 800*-W-****-ExR
	0Ex ia IIC T4...T2 X Ga	TCM 0450-*_*_*_*_*_*_*_*_*_*-ExR
KGS (Korea)	Ex d [ia] IIC T4	TCE 800*-W-****-ExK
	Ex ia IIC T4	TCM 0450-*_*_*_*_*_*_*_*_*_*-ExK



## 7.3. Technical Data

### 7.3.1. Technical Data TCM 0450/TCMH 0450 Transducer

<b>Measurement Mass Flow</b>	
Mass Flow Rate (max.)	450 kg/h [16.53 lb/min]
Accuracy	1 % of reading
Zero Stability	±0.1 % of full scale (0.45 kg/h) [±0.1 % of full scale (0.01653 lb/min)]
Max. zero offset drift with temperature change	0.001 % of reading per °C
Max. zero offset drift with pressure change	0.001 % of reading per bar
Repeatability	0.5 % of reading
<b>Measurement Temperature</b>	
Accuracy	±1.8 °F ±0.5 % of reading [±1 °C ±0.5 % of reading]
<b>Process and Environment</b>	
Connection	3/8 " Autoclave (MP)
Pressure Rating	1,050 bar [15,200 psi]
Process Temperature	Standard: -40 °F ... +212 °F [-40 °C ... +100 °C] Ex-Version: -40 °F ... +158 °F [-40 °C ... +70 °C]
Ambient Temperature	-40 °F ... +158 °F [-40 °C ... +70 °C]
Electrical Connection	Push-Pull connector
<b>General</b>	
Ingress Protection	IP65 (NEMA 4)
Tube Design	2 parallel
Tube Diameter Inside	2.4 mm
Tube Material	Sandvik Alloy HP 160
Manifold Material	1.4435 [AISI 316L]
Housing Material	1.4404 [AISI 316L]
Dimensions	see chapter 7.3.5
Weight	approx. 7.5 kg [16.5 lb]

## 7.3.2. Technical Data TCE 8000 Transmitter

General	
Supply Voltage	24 V DC or 100 ... 240 V AC (version dependent)
Power Consumption	max. 4 W (DC version) max. 11 W (AC version)
Environmental Conditions	<ul style="list-style-type: none"> <li>• Transient over voltages up to the levels of overvoltage category II</li> <li>• Temporary over voltages occurring on mains supply only</li> <li>• POLLUTION DEGREE 2</li> <li>• MAINS AC supply voltage fluctuations up to <math>\pm 10\%</math> of the nominal voltage</li> <li>• Altitude up to 2,000 m</li> </ul>
Reverse Polarity Protection	yes
Galvanic Isolation	2,500 V AC
Display	back-lit LCD screen, 132 x 32 dot
Programming	via front keyboard or Windows-based TRICOR configurator program (Modbus)
Interfaces	RS485 (Modbus RTU), Option HART®, Foundation Fieldbus® other options on request
Cable Glands	Suitable for $\varnothing 7 - 13$ mm cables Material: Brass/Ni plated (option: Stainless steel 1.4404 [AISI 316]) Thread: 2 x $\frac{1}{2}$ " NPT or 2 x M20 x 1.5
Dimensions	see chapter 7.3.5
Electrical Connections	cage clamp terminals
Sensor Cable Glands	Barrier cable gland: applied by manufacturer (thread: $\frac{1}{2}$ " NPT)
Housing Material	Aluminum diecast (option: 1.4404 [AISI 316L])
Protection class	IP65 (IP66/IP67 on request)
Weight:	with aluminum diecast housing: 3.8 kg [8.3 lb] with 3 m cable with 1.4404 [AISI 316L] housing: 6.15 kg [13.56 lb]
Temperature	ambient: -40 °C ... +70 °C [-40 °F ... +158 °F] storage and transport: -40 °C ... +80 °C [-40 °F ... +176 °F]
Analog Outputs	
Current Outputs (2x)	4 ... 20 mA passive, two-wire, isolated
Resolution	14 bit
Linearity	$\pm 0.05\%$ of full scale
Temperature Drift	0.05 % per 10 K
Load	< 620 $\Omega$ (at 24 V supply)
Output Value	programmable: flow, total, density, temperature
Pulse Output	
Frequency Range	0.5 - 10,000 Hz (in TOTAL mode: 0 - 100 Hz)
Output Signal	active push pull output for flow rate
Status In- and Output	
Status Output	push pull programmable (in FREQUENCY mode: 0.5 - 10,000 Hz)
Control Input	programmable



<b>Analog Input (option)</b>	
Input Type	4 ... 20 mA active for two-wire passive pressure sensor
Resolution	12 bit
Linearity	±0.05 % of full scale
Temperature Drift	0.05 % per 10 K
Supply Voltage	> 20 V (at 20 mA sensor current)

### 7.3.3. Technical Data TCE/TCM Cable

	<b>Standard cable</b>	<b>High temperature cable</b>
<b>General</b>		
Outer Diameter	8.70 mm ±0.2 mm	6,9 mm ±0,2 mm
Sheath	PUR	FEP
Colour	grey (RAL7032)	black
Labeling	UL (white)	—
RoHS	yes	yes
<b>Resistance</b>		
Flammability	flame-retardant (IEC 60332-1-2)	flame-retardant
Hydrolysis Resistance	hydrolysis resistance	—
Oil Resistance	oil resistance	oil resistance
<b>Laying</b>		
Range of Temperatures	moved: -50 °C to +70 °C [-58 °F to +158 °F] fixed: -40 °C to +80 °C [-40 °F to +176 °F]	-65 °C up to +180 °C [-85 °F up to +356 °F]
Bending Radius	moved: 85 mm (10xD) fixed: 42.5 mm (5xD)	moved: 71 mm (10xD) fixed: 35.5 mm (5xD)

### 7.3.4. Torque requirements

<b>Description</b>	<b>Torque</b>
Cable gland to housing	10 Nm
Enclosure lids	10 Nm
Wall bracket screws	10 Nm



### 7.3.5. Dimensional Drawings

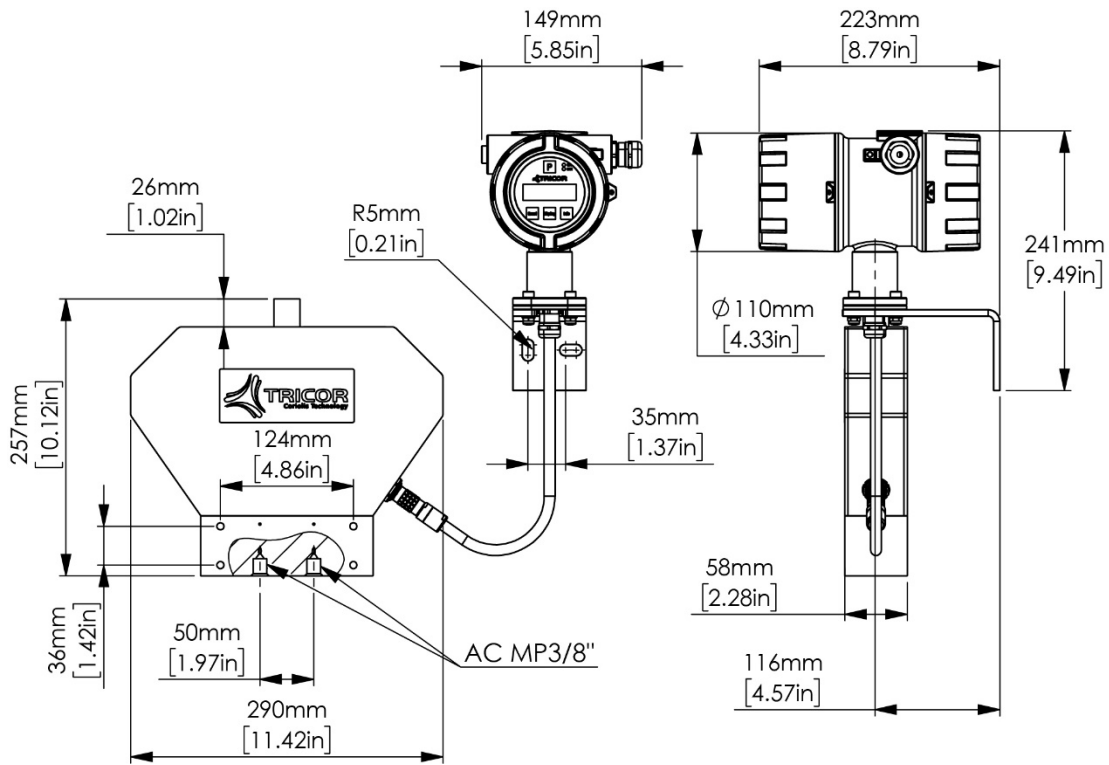

Fig. 18: Meter Dimensions TCMH 0450, Ex/Ex1

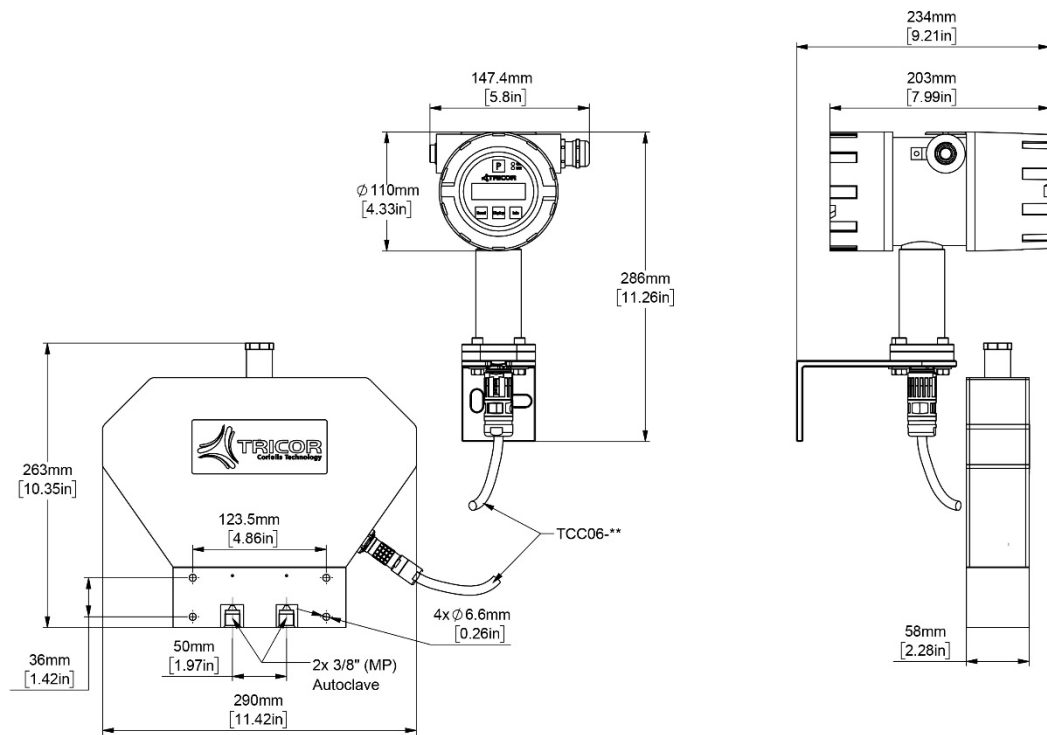

Fig. 19: Meter Dimensions TCMH 0450, Ex3



## 7.4. WEEE and RoHS

The TRICOR CLASSIC Mass Flow Meter described herein is not subject to the WEEE directive and the corresponding national laws. At the end of life forward the TCM to a specialized recycling company and do not dispose it off as domestic waste.

The TCM described herein fully complies with the RoHS directive.

## 7.5. Menu Structure

### 7.5.1. Main Menu

In the following table only the menus and parameters of the first two levels of the HMI menu structure are listed.

Level 1		Level 2		Mehr Informationen
No.	Name	No.	Name	
1	ZERO OFFSET			ZERO OFFSET Menu (Page 46)
2	DISPLAY	2.1	MASS TOTAL	DISPLAY - MASS TOTAL Menu (Page 47)
		2.2	MASS FLOW	DISPLAY - MASS FLOW Menu (Page 48)
		2.3	TEMPERATURE	DISPLAY - TEMPERATURE Menu (Page 50)
		2.4	PRESSURE	REF_Ref14857744 \h \* MERGEFORMAT DISPLAY - PRESSURE Menu (Page 51)
		2.5	DISP MODE	REF_Ref14857766 \h \* MERGEFORMAT DISPLAY - DISPLAY MODE Menu (Page 52)
3	SETUP	3.1	PARAMETER	SETUP - PARAMETER Menu (Page 54)
		3.2	FILTER	SETUP - FILTER Menu (Page 58)
		3.3	IN/OUTPUTS	SETUP - IN/OUTPUTS Menu (Page 59)
		3.4	DATA CONFIG	SETUP - DATA CONFIGURATION Menu (Page 68)
		3.5	RESET TOTAL	SETUP - RESET TOTAL Menu (Page 69)
		3.7	CLEAR LOGS	SETUP - CLEAR LOGS Menu (Page 69)
4	I/O-TEST	4.1	FREQ OUT	I/O-TEST - FREQUENCY OUT Menu (Page 70)
		4.2	CTRL OUT	I/O-TEST - CONTROL OUT Menu (Page 71)
		4.3	mA-OUT	I/O-TEST - ANALOG OUT Menu (Page 71)
		4.4	CTRL IN	I/O-TEST - CONTROL IN Menu (Page 72)
5	SERVICE	5.1	CALIBRATION	Calibration (Page 78)
		5.2	ACCESS CODE	Global Device Password (Page 81)
		5.3	RECALL FACT.	Reloading Factory Settings (Page 82)

Tab. 6: Main menu

### 7.5.2. Menu Item „DISPLAY“

Level 2		Level 3		Level 4	
No.	Name	No.	Name	No.	Name
2.1	MASS TOTAL	2.1.1	TOTAL UNITS		
		2.1.2	TOTAL DP		
2.2	MASS FLOW	2.2.1	FLOW UNITS		
		2.2.2	FLOW DP		
		2.2.3	DISP FILTER		
2.3	TEMPERATURE	2.3.1	TEMP UNITS		
		2.3.2	TEMP DP		
2.4	PRESSURE	2.4.1	PRESS.UNITS		
		2.4.2	PRESSURE DP		
2.5	DISP MODE	2.5.1	DISPLAY 1	2.5.1.1	SINGLE LINE
				2.5.1.2	DUAL LINE
		2.5.2	DISPLAY 1	2.5.2.1	SINGLE LINE
				2.5.2.2	DUAL LINE
		2.5.3	BACKLIGHT	2.5.3.1	ON
				2.5.3.2	OFF
		2.5.4	TIME MODE	2.5.4.1	FIXED
				2.5.4.2	ALTERNATE

Tab. 7: Menu items "DISPLAY"

### 7.5.3. Menu Item „SETUP“

Level 2		Level 3		Level 4	
No.	Name	No.	Name	No.	Name
3.1	PARAMETER	3.1.1	CUT OFF		
		3.1.2	RESET KEY		
		3.1.3	FLOW-DIREC		
		3.1.4	K-FACTOR		
		3.1.5	FAULT TIME		
		3.1.6	PRESS.COMP.		
		3.1.7	TOTAL COUNT		
		3.1.8	LANGUAGE		
3.2	FILTER	3.2.1	FLOW		
3.3	IN/OUTPUTS	3.3.1	FREQ OUT		
		3.3.2	CTRL OUT		
		3.3.3	mA-OUT		
		3.3.4	CTRL IN		
		3.3.5	mA-IN I1		
		3.3.6	INTERFACE		
		3.3.7	FAULT MODE		
3.4	DATA CONFIG	3.4.1	SAVE DATA		
		3.4.2	RECALL DATA		
3.5	RESET TOTAL				
3.6	CLEAR LOGS				

Tab. 8: Menu items "SETUP"



## 7.5.4. Menu Item „I/O-TEST“

Level 2		Level 3		Level 4	
No.	Name	No.	Name	No.	Name
4.1	FREQ OUT				
4.2	CTRL OUT				
4.3	mA-OUT	4.3.1	mA-OUT I1		
		4.3.2	mA-OUT I2		
		4.3.3	FAULT MODE		
4.4	CTRL IN				

Tab. 9: Menu items "I/O-TEST"

## 7.5.5. Menu Item „SERVICE“

Level 2		Level 3		Level 4	
No.	Name	No.	Name	No.	Name
5.1	CALIBRATION	5.1.1	METER VAR.		
		5.1.2	TEMP CALIB.		
		5.1.3	AIR CALIB.	4.1.3.1	AUTOMATIC
				4.1.3.2	MANUAL
		5.1.4	WATER CALIB.	4.1.4.1	AUTOMATIC
4.1.4.2	MANUAL				
5.1.5	PCZ MODE	4.1.5.1	OFF		
		4.1.5.2	ON		
5.2	ACCESS CODE				
5.3	RECALL FACT.				

Tab. 10: Menu items "SERVICE"

## 7.6. List of Figures

Fig. 1: Transducer TCM 0450/TCMH 0450 with wall-mountable transmitter electronics TCE 8001-W .....	6
Fig. 2: Rupture disc locations vary by the meter style .....	8
Fig. 3: Warning sticker found near the rupture disc on all meters .....	8
Fig. 4: Transducer TCM 0450/TCMH 0450 with wall-mount electronics TCE 8001-W .....	12
Fig. 5: Operating Elements TCE 80xx-W .....	13
Fig. 6: Bedienelemente TCM 0450/TCMH 0450 .....	14
Fig. 7: Electrical terminals TCE 8***-W and compact version .....	15
Fig. 8: Electrical terminals TCE 8***-W*-Ex .....	17
Fig. 9: Recommended Horizontal Installation .....	24
Fig. 10: Vertical Installation .....	24
Fig. 11: Vertical Installation .....	25
Fig. 12: Seals of the electronics housing and the connector .....	25
Fig. 13: Wiring diagram for power connections, DC operation .....	28
Fig. 14: Wiring diagram for power connections, AC operation .....	29
Fig. 15: Wiring diagram for digital I/O connections .....	30
Fig. 16: Wiring diagram for 4 ... 20 mA current loop .....	31
Fig. 17: Wiring diagram for 4 ... 20 mA current input .....	32
Fig. 18: Meter Dimensions TCMH 0450, Ex/Ex1 .....	89
Fig. 19: Meter Dimensions TCMH 0450, Ex3 .....	89

## 7.7. List of Tables

Tab. 1: List of errors (ERR Codes) .....	39
Tab. 2: List of warnings (WARN Codes) .....	39
Tab. 3: List of information (INFO Codes) .....	40
Tab. 4: List of service parameters .....	41
Tab. 5: List of TCM device info .....	42
Tab. 6: Main menu .....	90
Tab. 7: Menu items "DISPLAY" .....	91
Tab. 8: Menu items "SETUP" .....	91
Tab. 9: Menu items "I/O-TEST" .....	92
Tab. 10: Menu items "SERVICE" .....	92



## NORTH & SOUTH AMERICA

AW Lake Company  
2440 W. Corporate Preserve Dr. #600  
Oak Creek WI 53154 | USA  
+1 414 574 4300  
[sales@aw-lake.com](mailto:sales@aw-lake.com)  
[www.aw-lake.com](http://www.aw-lake.com)

## ASIA PACIFIC & MIDDLE EAST

KEM Küppers Elektromechanik GmbH  
Liebigstraße 5  
85757 Karlsfeld | Germany  
+49 8131 59391-0  
[info@kem-kueppers.com](mailto:info@kem-kueppers.com)  
[www.kem-kueppers.com](http://www.kem-kueppers.com)

## EUROPE (ROW)

KEM Küppers Elektromechanik GmbH  
Liebigstraße 5  
85757 Karlsfeld | Germany  
+49 8131 59391-100  
[sales@kem-kueppers.com](mailto:sales@kem-kueppers.com)  
[www.kem-kueppers.com](http://www.kem-kueppers.com)

## CHINA

KEM flow technology (Beijing) Co., Ltd.  
Rm. 906, Block C, Ruipu Office Bldg, No. 15  
HongJunYingNan Road  
Chaoyang District, Beijing 100012 | China  
+86 10 84929567  
[sales@kem-kueppers.com](mailto:sales@kem-kueppers.com)  
[www.kem-kueppers.cn](http://www.kem-kueppers.cn)