

## APPLICATION SPOTLIGHT

Accurate and Repeatable Bioreactor Gas Dosing

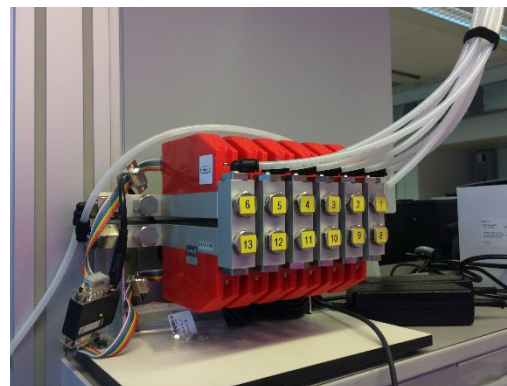

## Accurate and Repeatable Bioreactor Gas Dosing



### APPLICATION:

In bioreactors it is important to dose the gases accurately and reliably. Photanol is developing a biochemical process in which bacteria convert CO<sub>2</sub> into useful products. Challenges include controlling the dissolved oxygen, contaminations and the pH value. For this specific application it is required to regulate the acidity to 0.1 pH accurately. The pH value in a bio reactor is regulated by adding more or less CO<sub>2</sub>. Photanol regulates the mix of CO<sub>2</sub> and air with Vögtlin gas mass flow regulators.

### CHALLENGE:

Photanol uses one of the oldest organisms on the planet to produce sustainable building blocks for the chemical industry. Photosynthetic cyanobacteria were at the origin of all life on earth. And they are not demanding: sunlight and CO<sub>2</sub> are enough to keep them happy. Genetically modified bacteria are used to ensure that they excrete specific substances. In the lab, seventeen different products can already be produced with these cells.

In Photanol's laboratory in Amsterdam in the Netherlands there are dozens of bioreactors that test all kinds of variants of the process and of types of bacteria. In addition, the bacteria are also "grown" in bioreactors where the multiplication takes place in an ideal atmosphere (pH, oxygen, temperature, light, etc).

A new pilot project in the port of Amsterdam is currently underway. At Eemshaven, preparations are being made for a large demo plant on the grounds of partner Nouryon (formerly Akzo Nobel).

Accurate dosing of CO<sub>2</sub> and air plays an important role in the process. This allows you to control the pH value and thus the growth of the bacteria, which has a positive influence on the effectiveness of the process. And that is ultimately the biggest challenge: the conversion must be economically viable.

There was a need for a gas mass flow meter for the regulation of gases that are used in the production process:

- Automatically doses the required amount of gas
- Reliable and long-term stable (zero drift)
- Does not depend on pressure and temperature changes
- Provides accurate and repeatable results
- Digitally controlled
- Digital collection of measurement and diagnostic values





## Accurate and Repeatable Bioreactor Gas Dosing

### SOLUTION:

Biotechnology is a complex science, with many variables. So how do you filter the one variable that makes the difference? You must conduct many tests that vary one single variable and keep all other variables constant. Biotechnology is also a sensitive science. Small differences in process conditions can cause significant differences in the process. This is why instrumentation that is highly accurate and repeatable is essential.

In the past, bioreactors were equipped with variable flow meters (VA meters, with a glass tube and ball) and a manual valve. However, these older systems are not automatic and are very sensitive to changes in pressure and temperature. The modern gas mass flow controller (also called MFC) solves these limitations.

Thermal mass flow meters are good at measuring gases at low flow rates (1 mln/min to about 1000 ln/min). However, traditional mass flow meters (digital or otherwise) suffer from drift (accuracy shift) and therefore often need to be calibrated. The traditional capillary gas mass controllers use a very thin tube (about 0.1 mm) which makes the meter very sensitive to contamination. The Swiss Vögtlin mass flow meters use a radically different concept in which the measurement is performed by a sensor integrated in a chip (the MEMS).

After Photanol had properly defined what they needed, we delivered a customer-specific composition. For this, 12 Vögtlin gas mass flow controllers were used. Photanol controls them with LabView over Modbus and communicates with all modules through a single 2-wire cable. The Vögtlin gas mass flow controllers are also a standard part in the controllers of most bioreactors because they are very suitable for this kind of application.

---

*"This is a good example of how a good collaboration between a user (Photanol), a supplier (Teesing) and a manufacturer (Vögtlin) delivers a perfect result. Thanks to the precise definition of Photanol, the knowledge, experience and good cooperation between Teesing and Vögtlin, we are proud to be able to contribute to this positive development."*

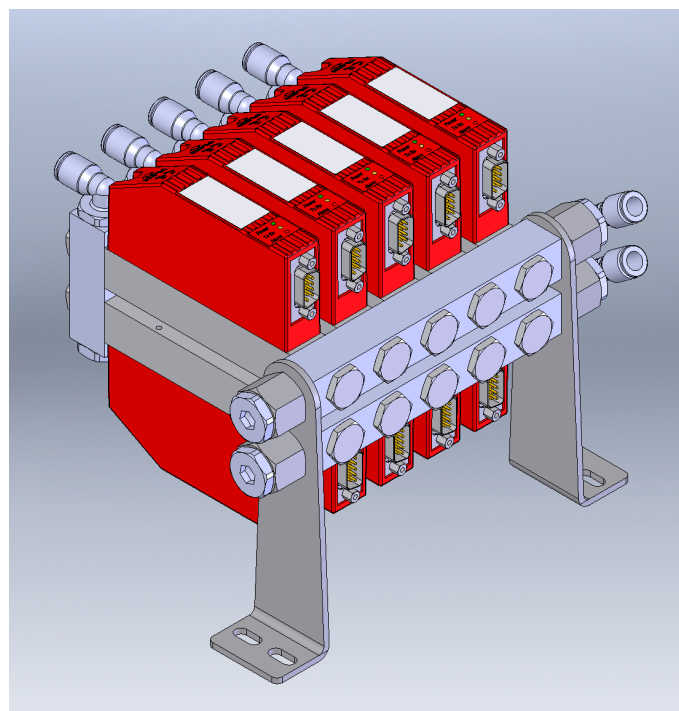

### **Algae, bacteria, blue-green algae??**

*Biochemistry started about 10 years ago with the use of algae for the production of biofuels. But that turned out to be (hardly) feasible. Currently, algae are only used for the production of Omega-3 fatty acids, dyes and proteins. The problem with algae is that they have to be broken down in order to 'harvest' the product. This costs a lot of energy and the algae dies as a result. The novelty of Photanol's technology lies in the use of these cyanobacteria. These are popularly called blue-green algae, but they are therefore bacteria. They excrete the end product themselves and stay alive. That sounds too good to be true and it is partly true. The cyanobacteria that occurs in nature only produces sugars and oxygen. DNA modified bacteria are used to make other products. Another challenge in this type of process in the so-called 'scale-up': the transition from a laboratory to an industrial application. This is complicated because many factors change on a larger scale. For example, the bacteria grow under the influence of light. This has been verified in the laboratory, but in practice we have to account for changing light levels from natural light. Finally, keeping the costs low is a challenge compared to the traditional chemical industry.*